

A Performance Evaluation of Oscillation Based Test in Continuous Time Filters

Eduardo Romero, Marcelo Costamagna, Gabriela Peretti, Carlos Marqués

Abstract—This work evaluates the ability of OBT for detecting parametric faults in continuous-time filters. To this end, we adopt two filters with quite different topologies as cases of study and a previously reported statistical fault model. In addition, we explore the behavior of the test schemes when a particular test condition is changed. The new data reported here, obtained from a fault simulation process, reveal a lower performance of OBT not observed in previous work using single-deviation faults, even under the change in the test condition.

Keywords—Testing, analog fault simulation, analog filter test, oscillation based test.

I. INTRODUCTION

CONSIDERABLE research has been devoted to the development of test methodologies for analog filters. Traditional test techniques verify functional specifications of filters like the limits of the pass-band and the attenuation in the stop-band. However, alternative test techniques have been formulated due to functional testing is time consuming and affects the cost of the product. Oscillation-Based Test (OBT) is an interesting test strategy for analog and mixed signal circuits that does not need resources for stimulus generation and requires simple circuits for the measurement of the test attributes. These two characteristics facilitate the implementation of built-in self-test structures or the reuse of the test circuitry for in-field testing.

Authors in [1] formerly propose OBT based on the conversion of a Circuit under Test (CUT) into an oscillator. In test mode, OBT evaluates some parameters of the oscillating signal, usually amplitude and frequency. It is assumed that a fault in the CUT will produce deviations in the evaluated parameters and consequently it will be observable.

OBT was successfully applied to filters in [2]-[5]. The referenced papers evaluate the ability of OBT for detecting single deviation faults in filters, and all of them obtain good values of fault coverage. These values are reached by adopting

single deviation fault models. When these models are used, nominal values are assigned to the non-faulty components, a simplification that allows implementing fault simulations in a very straightforward way. However, the metrics obtained following this approach do not take into account the natural variability of devices caused by many factors, such as manufacturing processes, aging and surrounding environment. This fact could lead to fault coverage values that overestimate or underestimate the efficacy of the test scheme.

Several researchers have developed parametric fault models and simulation techniques for analog circuits. In [6], it is considered that all circuit parameters can vary within their tolerance limits and only the faulty one adopts a value outside these limits. A similar single fault model and an algorithm for reducing the computational cost of fault-simulations are proposed in [7]. The authors of [8] propose a statistical test approach for analog circuits. For doing this task, they model a parametric fault in a process parameter as an impulse function (a mean shift with zero standard deviation) that falls into two neighboring regions of a fault-free tolerance window. Other authors [9], [10], define several metrics for evaluating the efficacy of test strategies under the hypothesis of parametric faults.

In [11], [12], the ability of OBT for detecting out of specification circuits is evaluated by using parametric fault models. It should be highlighted that the authors of these papers apply a functional test view. Additionally, the use of the strategy proposed in [11] requires a further test data processing for establishing the CUT specifications. This limits the use of the strategy for in-field testing and complicates the test scheme.

This paper proposes a new evaluation of OBT at structural level using a more realistic fault model. To this end, parametric faults are defined as out-of tolerance deviations in the process, circuit or system parameters [8]. Using these faults, the evaluation of OBT performance considers the statistical deviations in the values of the fault-free components in order to obtain more accurate metrics.

In addition, we explore the behavior of the test scheme used a test condition is changed, in order to establish if it is possible to improve it. For doing this task, we adopt two filters with quite different topologies as cases of study.

II. OBT IMPLEMENTATION

The application of OBT requires converting the CUT into a robust oscillator. We adopt non-linear oscillators that have been successfully applied in switched- capacitor filters [3],

G. Peretti and E. Romero are with Mechatronics Research Group, Facultad Regional Villa María, Universidad Tecnológica Nacional, Villa María, 5900, Argentina and with Electronics and Instrumentation Development Group, Facultad de Matemática, Astronomía y Física, Universidad Nacional de Córdoba, Córdoba, Argentina (phone: 54-353-4537500; fax: 54-353-4535498; e-mail: gecam@frvm.utn.edu.ar).

M. Costamagna is with Mechatronics Research Group, Facultad Regional Villa María, Universidad Tecnológica Nacional, Villa María, Argentina (e-mail: gecam@frvm.utn.edu.ar).

C. Marqués is with Electronics and Instrumentation Development Group, Facultad de Matemática, Astronomía y Física, Universidad Nacional de Córdoba, Córdoba, Argentina (e-mail: marques@famaf.unc.edu.ar).

[4]. Fig. 1 shows a conceptual diagram of the implemented oscillator, based on connecting a Non-Linear Block (NLB) from the main filter output to the filter input. NLB presents an abrupt characteristic, as Fig. 2 shows.

In Fig. 1, S1 to S4 are analogue switches employed for switching the filter from the test-mode to the normal-mode and vice versa. In normal mode, S1 and S3 are switched-on while S2 and S4 are switched-off. In this way, the filter input is connected to the normal input and the filter output is connected to the following stage of the application. In test mode, S1 and S3 are switched-off and S2 and S4 are switched-on. Consequently, the filter input is connected to the NLB output, and the system is configured as oscillator.

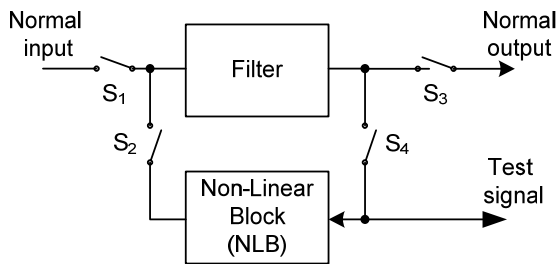

Fig. 1 Implementation scheme for OBT

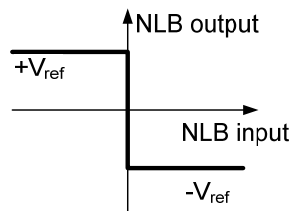

Fig. 2 NLB characteristic

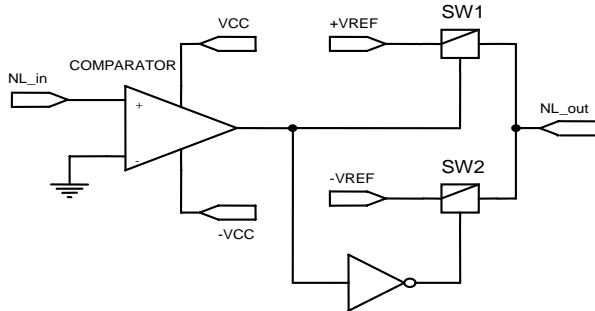

Fig. 3 Non-Linear circuit implementation

When the filters present attenuation for high frequencies, we employ the describing function approach [13] to analyze the system behavior and to find the oscillation parameters in an easy way. This method allows a rapid “first cut” design of the oscillators. The procedure for establishing the oscillation conditions using this approach is addressed elsewhere [3].

The non-linear circuit could be easily implemented by adopting the scheme depicted in Fig. 3. The comparator drives the analog switches SW1 and SW2 and obtains +Vref or –

Vref at the output of the non-linear circuit, depending on the polarity of the signal delivered by the CUT. Additional details can be found in [14].

III. FILTERS UNDER TEST

In order to evaluate the ability of OBT for detecting parametric faults, two filters are adopted as cases of study. The first one is a second-order band-pass filter [15], and it is referred as Filter1 (Fig. 4). The second one is a fourth-order low-pass filter [15] and it is referred as Filter2 (Fig. 5).

In test mode, the frequency and the amplitude of the output are measured, with a Vref value (Fig. 2) of 1V for both filters. We consider here that passive components could present parametric faults, while the feedback makes negligible the effects of this kind of faults in operational amplifiers. It is also assumed that catastrophic faults in operational amplifiers prevent the circuit oscillation and are easily detected.

IV. FAULT SIMULATION PROCESS

A. Limits of the Test Attributes for the Fault-Free Circuits

The test attributes exhibit a band of possible values for the fault-free circuits due to the variations in the circuit parameters inherent to the manufacturing process. The limits of these bands are called Statistical Tolerance Limits (STL) and are used for determining if a given fault can be detected by OBT.

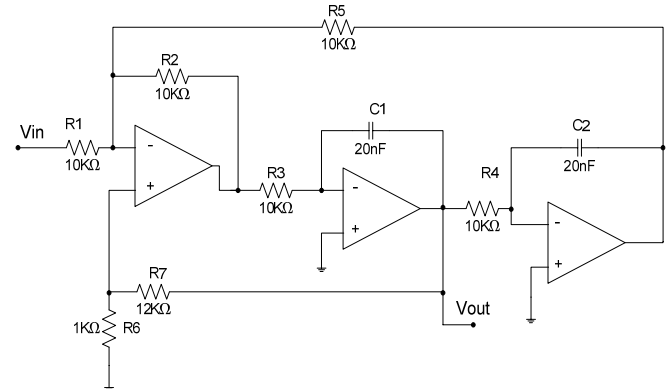

Fig. 4 Topology of Filter1

The setting of STL requires characterizing the statistical distributions of the amplitude and frequency. For this purpose, we model the value adopted by every passive component in the filters as a normally distributed random variable. The mean value of the distribution takes de nominal value shown in Figs. 4 and 5 while the standard deviation is characteristic of the manufacturing process (3.33% in our case study). It is assumed that there are no statistical correlations between the deviations in the components values.

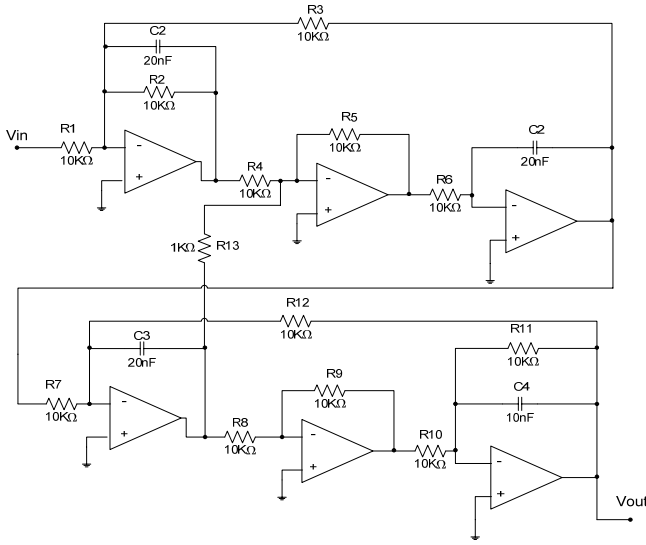

Fig. 5 Topology of Filter2

With this data, we implement a 500-sample Monte Carlo simulation in SPICE and obtain the frequency and amplitude values for each element of the sample. From the generated data, we obtain the statistical distribution of the test attributes.

A Shapiro-Wilk test [16] is used for determining the matching of fault-free distributions to Gaussian distributions. If the normality hypothesis is not rejected, we establish STL for a given confidence level using the mean and standard deviation of the distribution of the test parameter. If the hypothesis of data normality is rejected, it is possible to set limits independently of the distribution of the simulation results. However, for obtaining the same percentage of the population at the same confidence level, these limits usually require a sample size bigger than the required when the limits are established under normality assumption [16].

The Shapiro-Wilk test shows that the hypothesis of data normality cannot be rejected (at a 95% confidence level) for the amplitude, however the hypothesis is rejected for the frequency. According to these results, we set limits assuming normality for the amplitude; for the frequency, we set STL independently of the distribution.

Once the limits for accepting (or rejecting) a circuit are established two risks appear, one of them is to reject a fault-free circuit, the other one is to accept a faulty circuit. Moving the limits produces a decrement of one of the errors at the cost of increasing the other [6]. In this paper, we chose limits that diminish the probability of rejecting a fault-free filter, but increase the probability of accepting faulty circuits.

The lower and the upper STL are shown in Table I for both filters. These limits are set considering the 99.0% of the population, at a confidence level of 95%. The confidence level is the lowest obtained from the statistical distributions of the two test attributes.

B. Adopted Fault Model

For evaluating the ability of OBT for detecting deviation faults in the passive components, we adopt the fault model

proposed by Saab et al. [6]. This model considers that only one component can be faulty (single fault assumption) while the others adopt random values within their tolerance bands (obtained from their statistical distributions). A fault is introduced by assigning to the component a deterministic value outside its tolerance band. Fig. 6 illustrates this concept for a generic R_i component. In our experiments, we establish faults as a deviation of the component nominal value. Particularly, we consider 10 different deviation faults (df), $\pm 10\%$, $\pm 20\%$, $\pm 30\%$, $\pm 40\%$ and $\pm 50\%$ of the component nominal value.

TABLE I
STL OF TEST ATTRIBUTES FOR BOTH FILTERS UNDER STUDY

Test Attribute	Lower limit	Upper limit
Filter1 frequency (Hz)	649.97	773.98
Filter1 amplitude (V)	4.10	5.77
Filter2 frequency (kHz)	1.24	1.59
Filter2 amplitude (V)	0.34	0.69

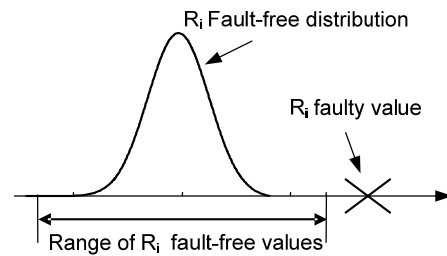

Fig. 6 Normal distribution and faulty value for a R_i component

C. Fault Detection Probability

The fault injection process generates 500 different instances of the filter under study. Each instance is obtained when a df value is assigned to the faulty component of the CUT, while the others adopt random values (with Gaussian distribution) within their tolerances. The fault injected in the component during simulation is declared as detected when the circuit presents test attribute values beyond STL. We use the following estimator to evaluate the fault detection probability:

$$FDP_i(df) = \frac{NDF_i}{NIF_i} \quad (1)$$

In (1), $FDP_i(df)$ denotes the probability of detecting the deviation fault (df) injected in any component (R_i or C_i). NDF_i is the sum of the detected faults for each component and NIF_i is the sum of the injected faults in the components, which is equivalent to the dimension of the generated sample.

In addition to the metric (1), we adopt for a global characterization of OBT the Fault Coverage (FC) value suggested by [7]. FC is defined as the average of the fault detection probabilities obtained for each deviation level (df):

$$FC(df) = \sum_{i=1}^n \frac{FDP_i(df)}{n} \quad (2)$$

In (2), $FC(df)$ is the fault coverage for the df deviation fault and n is the number of components considered in the fault injection. In contrast with FDP , this metric allows a global evaluation of OBT, but it is not useful to reveal hard-to-test components.

D. Fault Simulation Results

Table II reports FDPs for each component and for each injected fault in Filter1. In this table, values higher or equal to 70% have been highlighted. In this work, we consider that this level is the minimum acceptable FDP for each component individually considered. From the table, it is observed better FDPs for negative deviations. For positive deviations, only R_1 , R_2 , R_6 and R_7 present values higher than 70%. Additionally, it is observed that all the components exhibit low FDPs for small deviations in the component values. This suggests that the scheme could be applied to this filter when the test is focused on the detection of wide deviation faults (near catastrophic).

For obtaining a more compact OBT performance metric at

component level, we average the component FDP. This value is named FDP_{av} and is reported in the last row of Tables II and III. FDP_{av} is useful for comparing FDPs obtained under different experimental conditions (to be detailed in Section V), when the use of the whole set of FPD values becomes complicated. From the data reported in the table, it is observed that FDP_{av} values are low for all the filter components.

Table III depicts the simulation data for Filter2. The table shows a behavior of FDP values similar to the ones obtained in Filter1. Additionally, FDPs are low for positive deviations, for all the components. In this sense, the performance is poorer than the observed in Filter1. As expected, FDP_{av} values are low for all the components.

Table IV depicts the FC values for both filters. As expected from the previously reported data, we observe good FC values only for wide negative deviations. For the most of the injected faults, the FC has to be considered as poor. The average value of FC only reaches 42.5% and 26.24% for Filter1 and Filter2 respectively.

TABLE II
FDP VALUES (%) FOR FILTER1

Df (%)	R ₁	R ₂	R ₃	R ₄	R ₅	R ₆	R ₇	C ₁	C ₂
-50	100	99.2	100	99.2	100	100	100	100	89.2
-40	95.2	85.4	94.2	95.0	97.2	100	100	93.0	86.4
-30	56.2	32.0	54.0	56.2	58.4	93.2	90.4	58.2	62.2
-20	16.4	5.0	15.2	12.5	14.4	46.2	23	14.0	26.0
-10	3.2	0.2	1.8	0.8	1.0	4.2	4.8	2.4	15.2
10	0.0	0.8	1.2	0.0	0.2	0.2	6.8	1.0	0.8
20	5.0	11.6	2.4	3.2	4.0	10.0	25.0	2.2	7.2
30	26.2	28.6	10.2	11.0	14.2	46.6	63.8	7.2	24.4
40	51.4	52.2	20.0	23.2	28.0	80.8	93.0	21.4	44
50	72.6	81.0	41.4	45.2	52.2	100	100	42.2	64.2
FDP_{av}	42.6	40.0	34.0	34.6	36.9	61.5	60.6	34.1	42.0

TABLE III
FDP VALUES (%) FOR FILTER2

Df(%)	R ₁	R ₂	R ₃	R ₄	R ₅	R ₆	R ₇	R ₈	R ₉	R ₁₀	R ₁₁	R ₁₂	R ₁₃	C ₁	C ₂	C ₃	C ₄
-50	100	92.8	93.8	84.2	98.6	100	100	85.2	75.2	85.6	94.8	97.4	78.2	49.6	100	100	34.2
-40	98.2	48.4	46.2	38.2	84.6	90.0	85.2	34.2	37.2	30.4	60.6	73.8	23.6	14.8	90.6	92.2	13.4
-30	70.2	16.2	20.0	22.8	50.8	58.6	49.4	18.2	15.0	20.7	21.6	20.4	15.4	9.6	42.8	40.2	8.2
-20	18.4	4.2	2.0	3.6	16.8	8.2	10.8	5.2	4.2	2.8	3.8	1.0	0.8	2.4	6.6	6.8	2.4
-10	4.8	2.2	1.0	1.8	0.8	2.4	5.2	2.0	0.8	2.8	1.0	1.2	1.8	1.0	2.0	2.6	0.8
10	1.2	3.4	0.8	3.2	1.8	0.0	1.0	1.2	2.4	0.0	1.6	1.6	0.0	0.2	3.0	3.6	1.0
20	4.2	6.2	5.4	4.4	3.8	10.6	6.2	3.0	4.2	2.2	3.8	3.8	2.2	3.8	7.6	11.2	4.0
30	10.6	18.2	10.2	5.0	33.4	30.6	10.2	10.6	11.2	8.2	16.5	11.8	7.2	9.8	29.2	27.6	10.2
40	23.8	40.8	13.2	15.2	55.8	48.8	15.2	12.2	12.0	10.0	34.8	18.6	9.2	11.0	45.6	44.8	12.4
50	51.2	51.6	23.0	25.8	60.2	63.6	35.4	17.4	19.2	16.2	55.2	23.2	13.0	17.2	65.6	62.6	20.8
FDP_{av}	38.3	28.4	21.6	20.4	40.7	41.3	31.9	18.9	18.1	17.9	29.4	25.3	15.1	11.9	39.3	39.2	10.7

V. EVALUATION OF OBT PERFORMANCE FOR DIFFERENT VREF VALUES

The variation of V_{ref} (Fig. 1) is a relatively straightforward way for changing the test conditions of the OBT scheme, and it could improve the FC values. With the aim of exploring this possibility, we change V_{ref} in both oscillators.

Due to the oscillation conditions change when V_{ref} does, it is necessary a new characterization of the oscillators. For this

purpose, we apply the procedure previously reported in Section IV-A for obtaining STL for fault-free conditions. The fault injection and simulation procedure is not changed. FC is used as comparison parameter between the different oscillation conditions.

TABLE IV
FC VALUES FOR BOTH FILTERS

Df(%)	FC (%) Filter1	FC (%) Filter2
-50	98.6	85.8
-40	94.1	56.1
-30	62.2	30.2
-20	19.1	5.9
-10	3.7	2
10	1.2	1.6
20	7.8	5
30	25.8	14.8
40	46	25.3
50	66.5	35.7

TABLE V
FC FOR FILTER1 UNDER SELECTED VREF VALUES

Df(%)	FC (%) Vref=0.5V	FC (%) Vref=1V	FC (%) Vref=2V
-50	99.1	98.6	100
-40	93.1	94.1	94.8
-30	62.2	62.2	64.0
-20	17.6	19.1	20.3
-10	2.4	3.7	2.9
10	1.3	1.2	1.8
20	6.6	7.8	9.0
30	21.4	25.8	25.8
40	41.2	46	47.4
50	63.5	66.5	65.0

TABLE VI
FC FOR FILTER 2 UNDER SELECTED VREF VALUES

Df(%)	FC (%) Vref=1V	FC (%) Vref=2V	FC (%) Vref=4V
-50	85.8	79.8	83.1
-40	56.1	56.9	57.2
-30	30.2	24.1	24.9
-20	5.9	7.5	7.1
-10	2	2	2
10	1.6	1.5	1.2
20	5	6.2	3.6
30	14.8	14.8	8.5
40	25.3	24.1	25.4
50	35.7	40.9	43.2

Tables V and VI report the FC values for Filter1 and Filter2 respectively, under different levels of Vref. In most cases, the data of the tables does not show significant differences in FC when Vref changes. The average of Filter1 FC reaches 40.84%, 42.5% and 43.1% for Vref values of 0.5V, 1V and 2V respectively. For Filter2, we observe a behavior similar to the observed in Filter1, i.e. small changes in FC with variations in Vref. For this case, the averages of FCs reach 40.84% (Vref=1V), 42.5% (Vref=2V) and 43.1% (Vref=4V).

Even if a slightly better performance appears for the highest Vref value, the FC values still preclude considering OBT as a good test option for these filters.

As it was mentioned previously, FC allows a straightforward comparison between the different oscillation conditions. However, this parameter does not expose the OBT performance for detecting deviations in each particular

component. The change in the experimental conditions could produce an increase in the FDPs of some components but a reduction in others. This could cause that FC does not experiment significant changes in average but does not show if successive test sessions with different Vref values improve the test performance.

For exploring the above-mentioned possibility, we report in Table VII FDP_{av} in Filter1 for the same experimental conditions. From the data reported in the table, we observe no significant improvements that justify the application of successive test sessions with different Vref values. This would imply an increase in both the test circuital resources and test time. Similar behavior can be observed in Table VIII for Filter2.

TABLE VII
FDP_{AV} FOR SELECTED VREF VALUES, FILTER1

Component	FDP _{av} (%) Vref=0.5V	FDP _{av} (%) VREF=1V	FDP _{av} (%) VREF=2V
R ₁	40.15	42.6	46.68
R ₂	39.24	40	40.4
R ₃	33.08	34	33.41
R ₄	34.4	34.6	35.2
R ₅	36.08	36.9	37.77
R ₆	57.71	61.5	62.08
R ₇	59.64	60.6	63.46
C ₁	34.28	34.1	33.24
C ₂	33.28	42	34.84

TABLE VIII
FPDF_{AV} FOR SELECTED VREF VALUES, FILTER2

Component	FDP _{av} (%) Vref=0.5V	FDP _{av} (%) Vref=1V	FDP _{av} (%) Vref=2V
R ₁	38.26	39.28	42.67
R ₂	28.38	30.96	33.84
R ₃	21.56	21.46	21.54
R ₄	20.42	18.80	18.58
R ₅	40.66	39.06	31.90
R ₆	41.28	44.04	39.66
R ₇	31.86	32.24	33.56
R ₈	18.92	18.9	19.31
R ₉	18.14	16.48	15.02
R ₁₀	17.89	17.26	17.18
R ₁₁	29.37	29.98	32.75
R ₁₂	25.28	18.30	21.88
R ₁₃	15.14	12.06	13.38
C ₁	11.94	8.70	9.02
C ₂	39.30	44.16	37.98
C ₃	39.16	44.64	38.68
C ₄	10.74	7.95	8.92

VI. CONCLUSIONS

The simulation data provide detailed information about the OBT performance at component level. From these ones, we conclude that the test scheme could be applied only for detecting wide deviation faults, near catastrophic ones. The other two metrics used for comparison and decision, FC and FDP_{av} also show that the scheme is suitable only if the test is focused in the detection of wide deviation faults.

The FDP_{av} and FC values obtained under different Vref values shows not significant variations at component level. This means that it is not recommended the implementation of successive test sessions for increasing the FDPs of each component. In this sense, the complexity of the required circuitry and the increase in the test time does not justify the marginal increase in the test performance.

The low values of the adopted metrics strongly contrasts with the previously reported by using deterministic fault models in similar test schemes. This suggests that OBT should be carefully evaluated by using statistical fault models for deciding its usefulness for testing a given circuit.

REFERENCES

- [1] K. Arabi, K., and B. Kaminska, "Oscillation-Test Strategy for Analog and Mixed-Signal Integrated Circuits," in *Proc. of the 14th. VLSI Test Symposium*, 1996, pp. 476-482.
- [2] G. Huertas, D. Vázquez, E. Peralías, A. Rueda, and J. Huertas, "Practical Oscillation-Based Test of Integrated Filters," *IEEE Design & Test of Computers*, vol. 19, pp. 64-72, Nov/Dec 2002.
- [3] E. Romero, G. Peretti, G. Huertas, and D. Vázquez, "Test of Switched-Capacitor Ladder Filters Using OBT," *Microelectronics J.*, vol. 36, pp. 1073-1079, Dec. 2005.
- [4] J. Catalano, G. Peretti, E. Romero, and C. Marqués, "Exploring the Ability of Oscillation Based Test for Testing Continuous-Time Ladder Filters", in *Proc. 2006 7th. Int. Symposium on Quality Electronic Design*, pp. 543-550.
- [5] P. Petrashin, G. Peretti, and E. Romero, "OBT Implementation on an OTA-C Band-Pass Filter," in *Proc. 2010 11th. Int. Symposium on Quality Electronic Design*, pp. 271-276.
- [6] K. Saab, N. Ben-Hamida, and B. Kaminska, "Parametric Fault Simulation and Test Vector Generation," in *Proc. Conf. on Design, Automation and Test in Europe*, 2000, pp. 650-656.
- [7] A. Khouas, and A. Derieux, "Fault Simulation for Analog Circuits under Parameter Variations," *J. Electron Test*, vol. 16, pp. 269-278, June 2000.
- [8] F. Liu and S. Ozev, "Statistical Test Development for Analog Circuits under High Process Variations," *IEEE Trans. Comput. Aided Des Integr. Circuits Syst.*, vol. 36, no.8, pp. 1465-1477, August 2007.
- [9] S. Sunter, and N. Nagi, "Test metrics for Analog Parametric Faults", in *Proc. 17th. VLSI Test Symposium*, 1999, pp. 226-234.
- [10] A. Bounceur, S. Mir, E. Simeu, and L. Rolíndez, "Estimation of Test Metrics for the Optimisation of Analogue Circuit Testing," *J. Electron Test*, vol. 23, pp 471-484, Dec. 2007.
- [11] A. Raghunathan, J. Chun, J. Abraham, and A. Chatterjee, "Quasi-Oscillation-Based Test for Improved Prediction of Analog Performance Parameters," in *Proc. Int. Test Conf.*, 2004, pp. 252-261.
- [12] A. Chaehoi, Y. Bertrand, L. Latorre, P. Nouet, "Improving the Efficiency of the Oscillation-Based Test Methodology for Parametric Faults," in *Proc. 4th IEEE Latin American Test Workshop*, 2003, pp. 234-237.
- [13] J. Gibson, *Nonlinear Automatic Control*. Japan: McGraw-Hill, 1963, pp. 431-436.
- [14] G. Peretti, E. Romero, and C. Marqués, "Test of Nuclear Shapers Using Oscillation-Based Test," *Latin American Applied Research*, vol. 37, pp. 163-170, July 2007.
- [15] B. Kaminska, K. Arabi, I. Bell, P. Goteti, J. Huertas, B. Kim, A. Rueda, and M. Soma, "Analog and Mixed-Signal Benchmark Circuits – first Release," in *Proc. of the Int. Test Conference*, 1997, pp.183-190.
- [16] A. Mitra, *Fundamentals of Quality Control and Improvement*. Upper Saddle River, NJ: Prentice Hall, 1998.