

TOMAS  
ACOSTA

# E.S.T.U

Escuela Secundaria Técnica y Universitaria ubicada en zona sur  
de la ciudad de Córdoba

JOAQUIN  
CABANILLAS



ESTU



ARQUITECTURA 6 C



## NUESTRO ENFOQUE

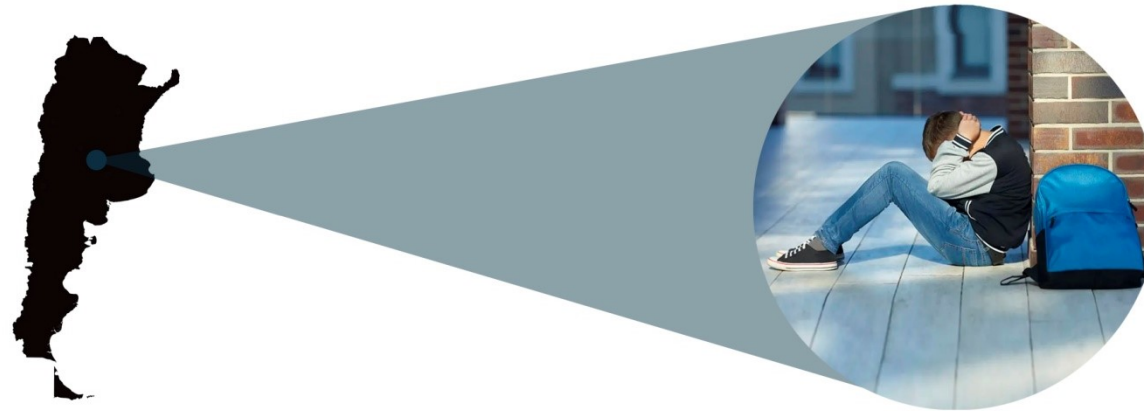

**Deserción  
Escolar**



## NUESTRO ENFOQUE

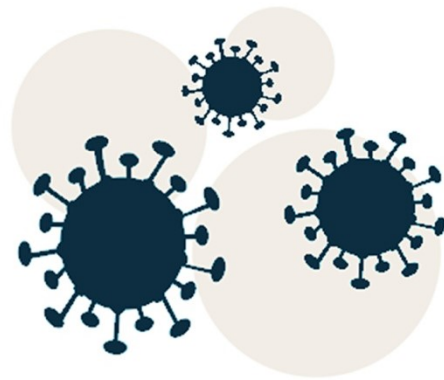
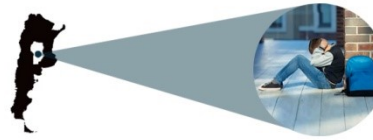

Pandemia  
Covid 19

Ciudad  
de  
Córdoba



## NUESTRO ENFOQUE



**Trabajo  
Informal**



**Escasez  
de técnicos y  
profesionales**



**Desigualdad  
de  
oportunidades**



## NUESTRO ENFOQUE



Trabajo  
Informal



Escasez  
de técnicos y  
profesionales



Desigualdad  
de  
oportunidades



## INSTITUCIONES EDUCATIVAS



Educación  
Terciaria



- 1 Colegio Nacional Monserrat  
UNC
- 2 Escuela Superior de Comercio  
Manuel Belgrano | UNC

INSTITUCIONES EDUCATIVAS  
Colegio Nacional Monserrat  
UNC

1687

Arquitectura  
Colonial

1500  
Estudiantes

Secundario  
+  
Terciario



## INSTITUCIONES EDUCATIVAS

### Escuela Superior de Comercio Manuel Belgrano | UNC

1936

Arquitectura  
Brutalista

1800  
Estudiantes

Secundario  
+  
Terciario





## AREA DE INTERVENCION

Usuario / Estudiante

Alejado del  
Centro

Agrupacion

Marginado

Falta de  
Infraestructura



## LOCALIZACIÓN



República Argentina

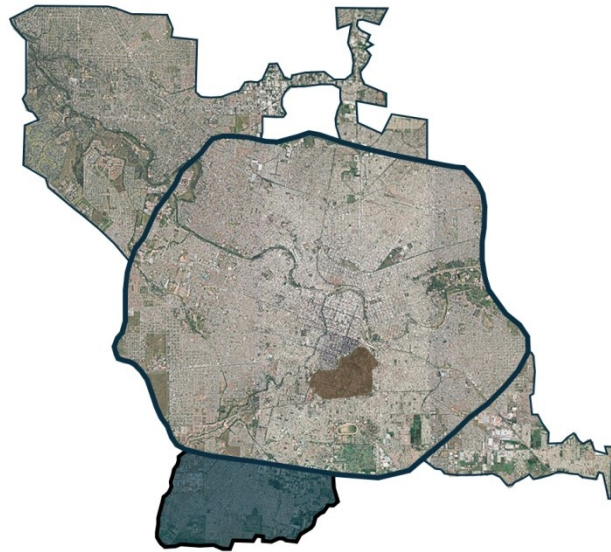

Ciudad de Córdoba



Barrio Comercial



## LOCALIZACIÓN



## Características

120.000  
Habitantes

Área más  
poblada de  
la ciudad

Conexión  
Directa

Fuera del anillo  
de circunvalación

13  
Minutos

Cercanía con  
Ciudad Universitaria





01 | ESCALA FRAGMENTO

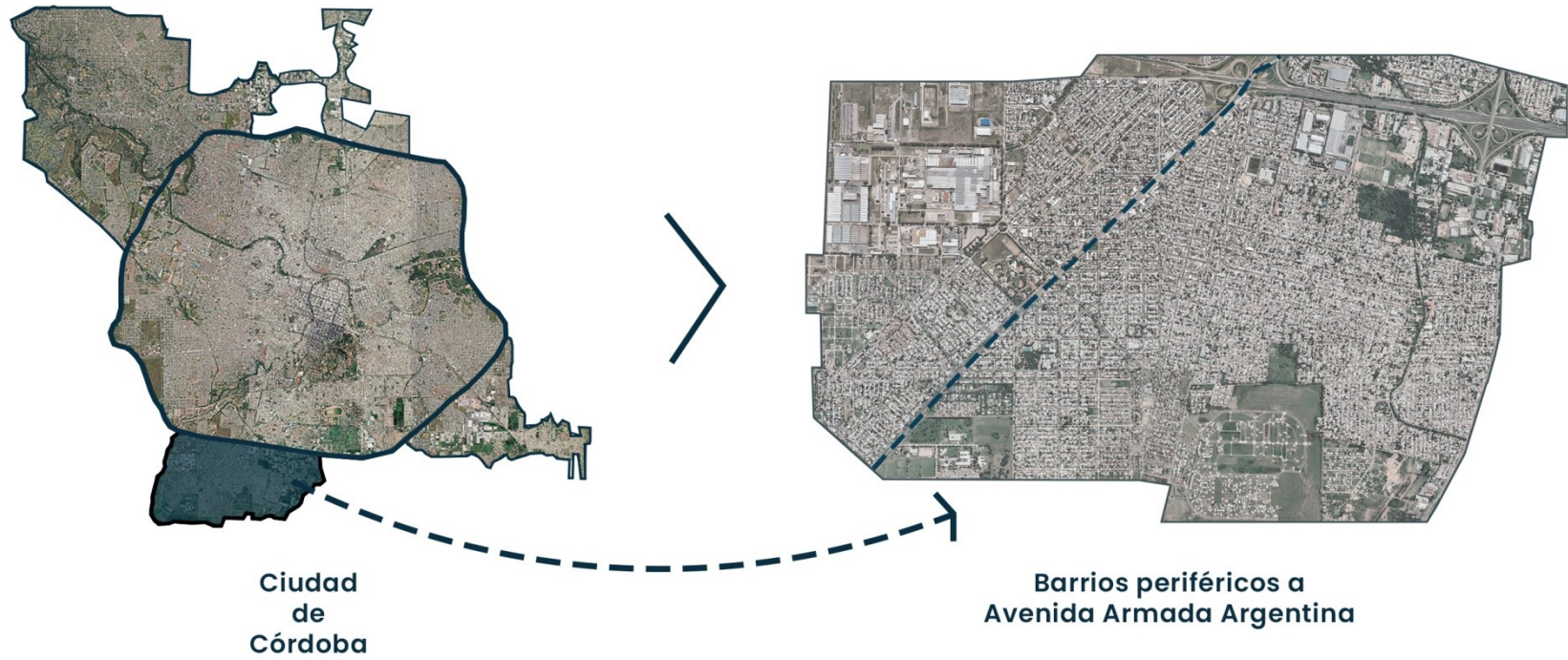



# 01 | ESCALA FRAGMENTO

1  
Circulación

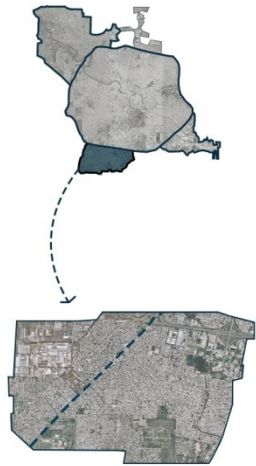



# 01 | ESCALA FRAGMENTO

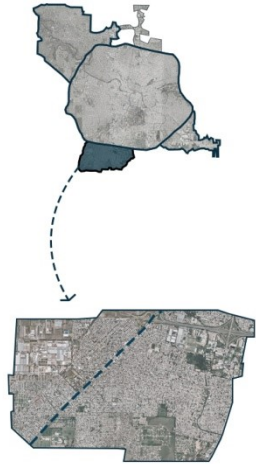

- 1  
Circulación
- 2  
Elementos Naturales





# 01 | ESCALA FRAGMENTO

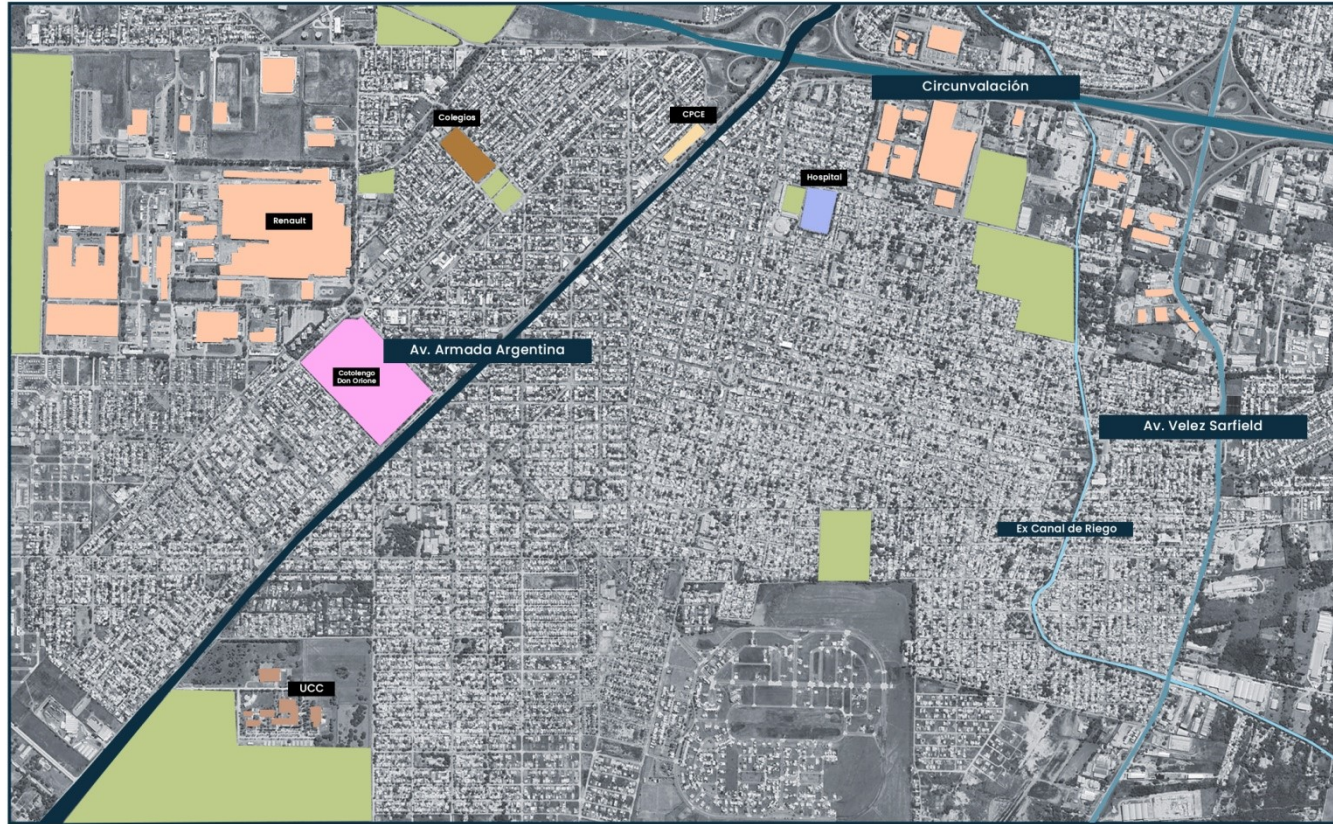
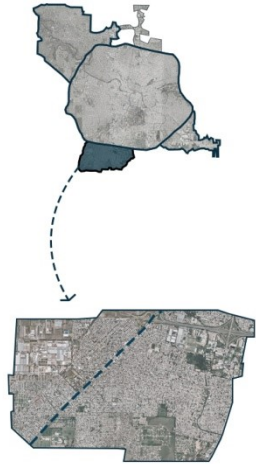

- 1  
Circulación
- 2  
Elementos Naturales
- 3  
Equipamientos





# 01 | ESCALA FRAGMENTO

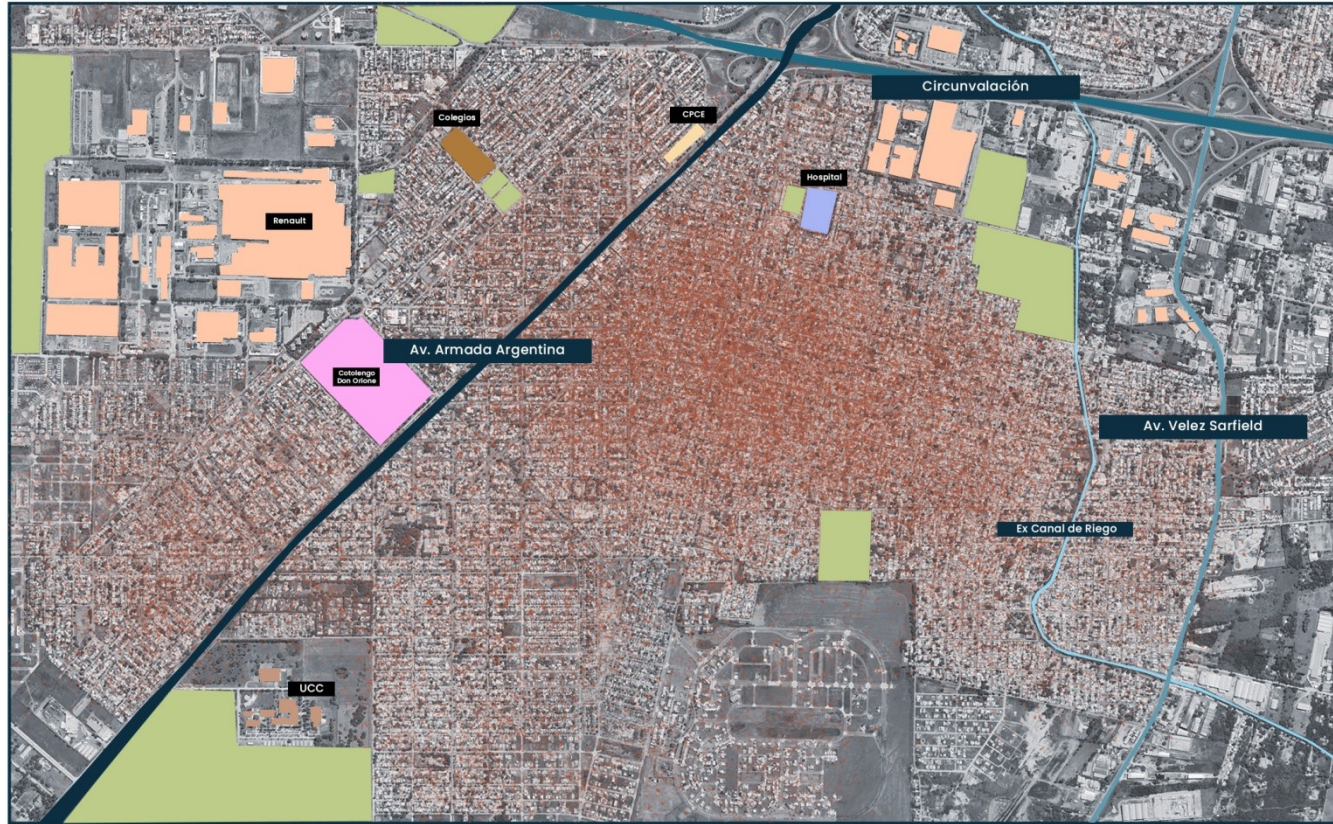
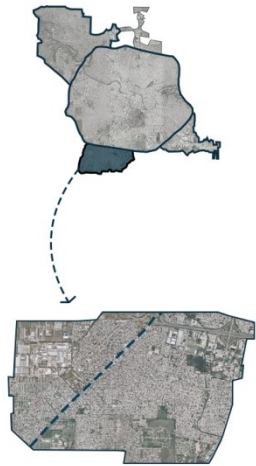

- 1  
Circulación
- 2  
Elementos Naturales
- 3  
Equipamientos
- 4  
Densidad Tejido





## 01 | ESCALA FRAGMENTO

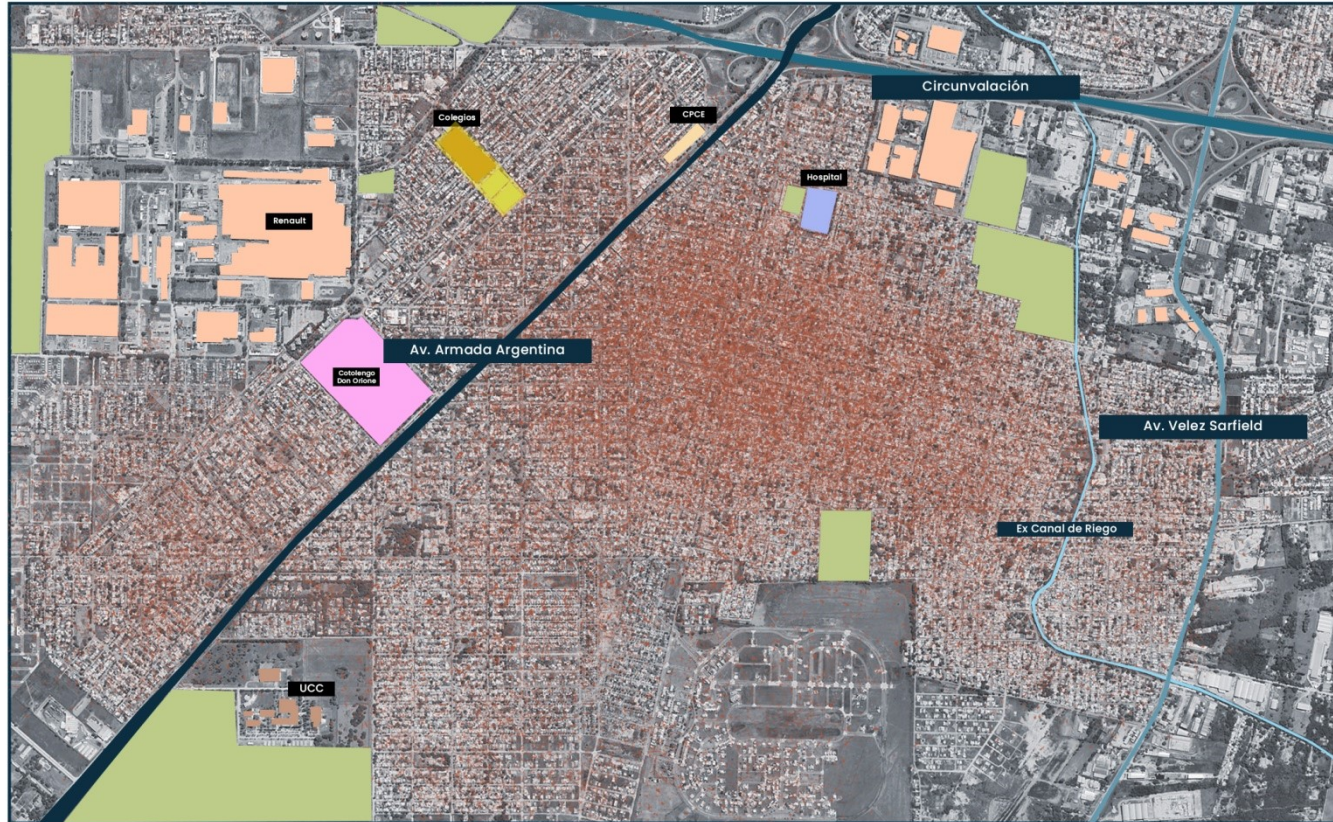
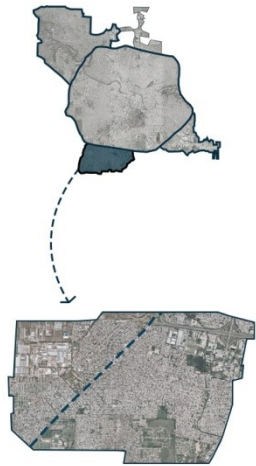

- 1  
Circulación
- 2  
Elementos Naturales
- 3  
Equipamientos
- 4  
Densidad Tejido
- 5  
Sector



## 02 | ESCALA SECTOR



Fragmento



Sector





## 02 | ESCALA SECTOR



1  
Conexiones



## 02 | ESCALA SECTOR



1  
Conexiones

2  
Equipamientos





## 02 | ESCALA SECTOR



**1**  
Conexiones

**2**  
Equipamientos

**3**  
Entorno  
Inmediato



## 02 | ESCALA SECTOR



1  
Conexiones

2  
Equipamientos

3  
Entorno  
Inmediato

4  
Sitio





### 03 | ESCALA SITIO



Escala Sector

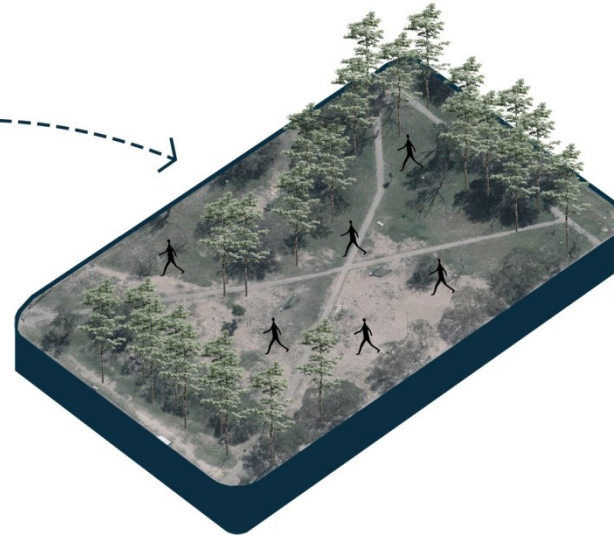

Sitio



### 03 | ESCALA SITIO

#### Análisis de Sitio

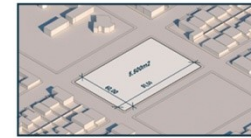
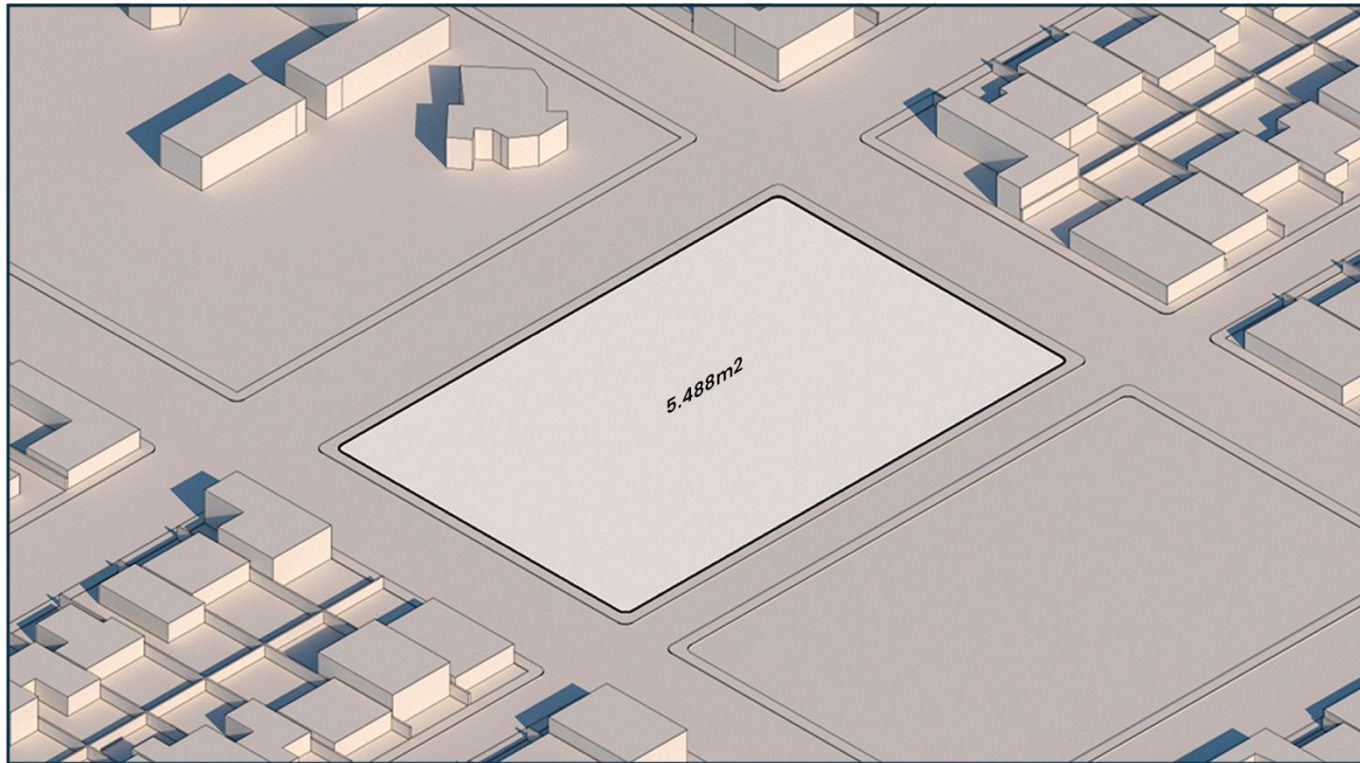

Sitio





### 03 | ESCALA SITIO

#### Análisis de Sitio

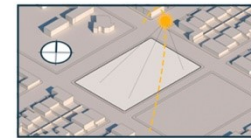
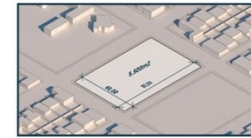
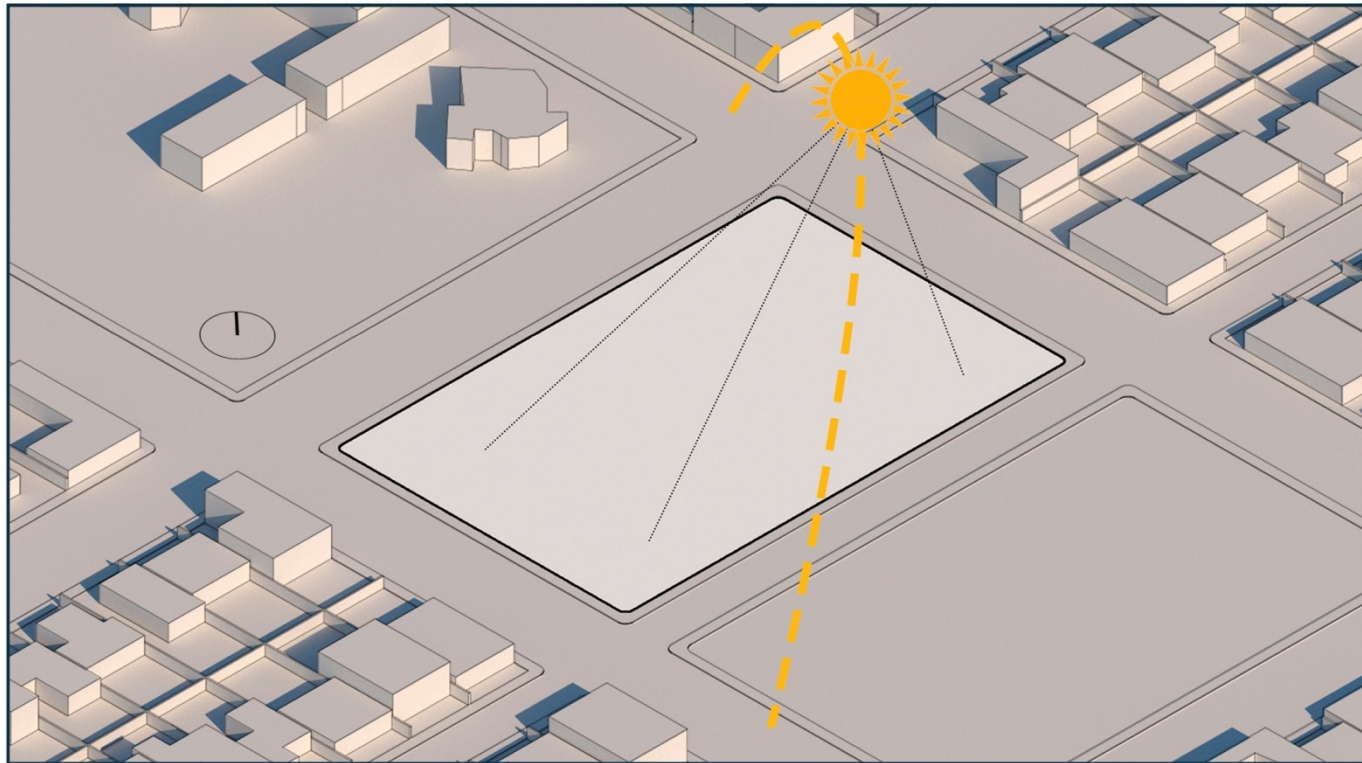

Asoleamiento

### 03 | ESCALA SITIO

#### Análisis de Sitio

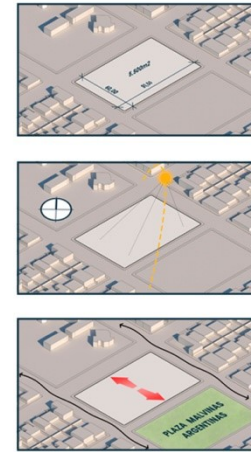
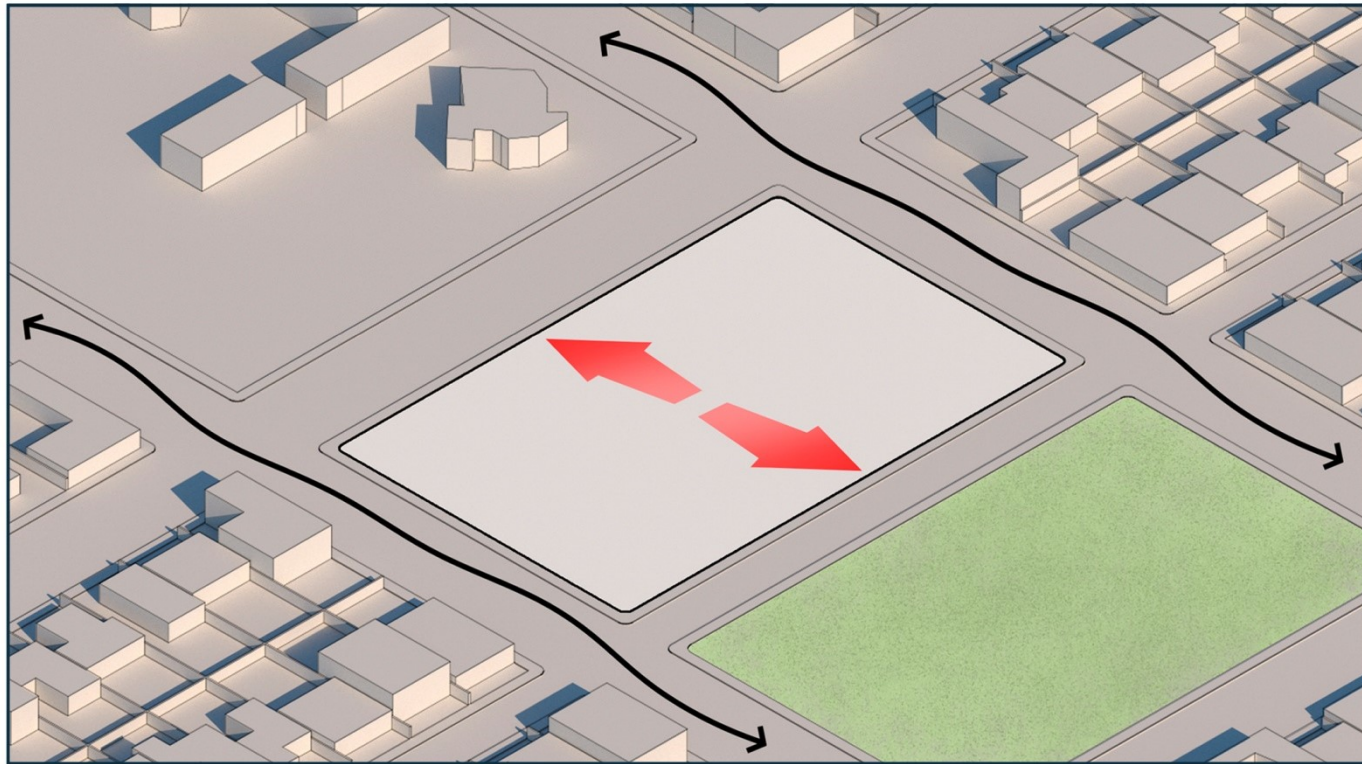

Conexiones





### 03 | ESCALA SITIO

#### Análisis de Sitio

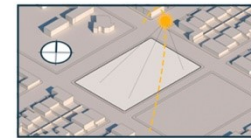
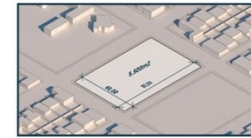
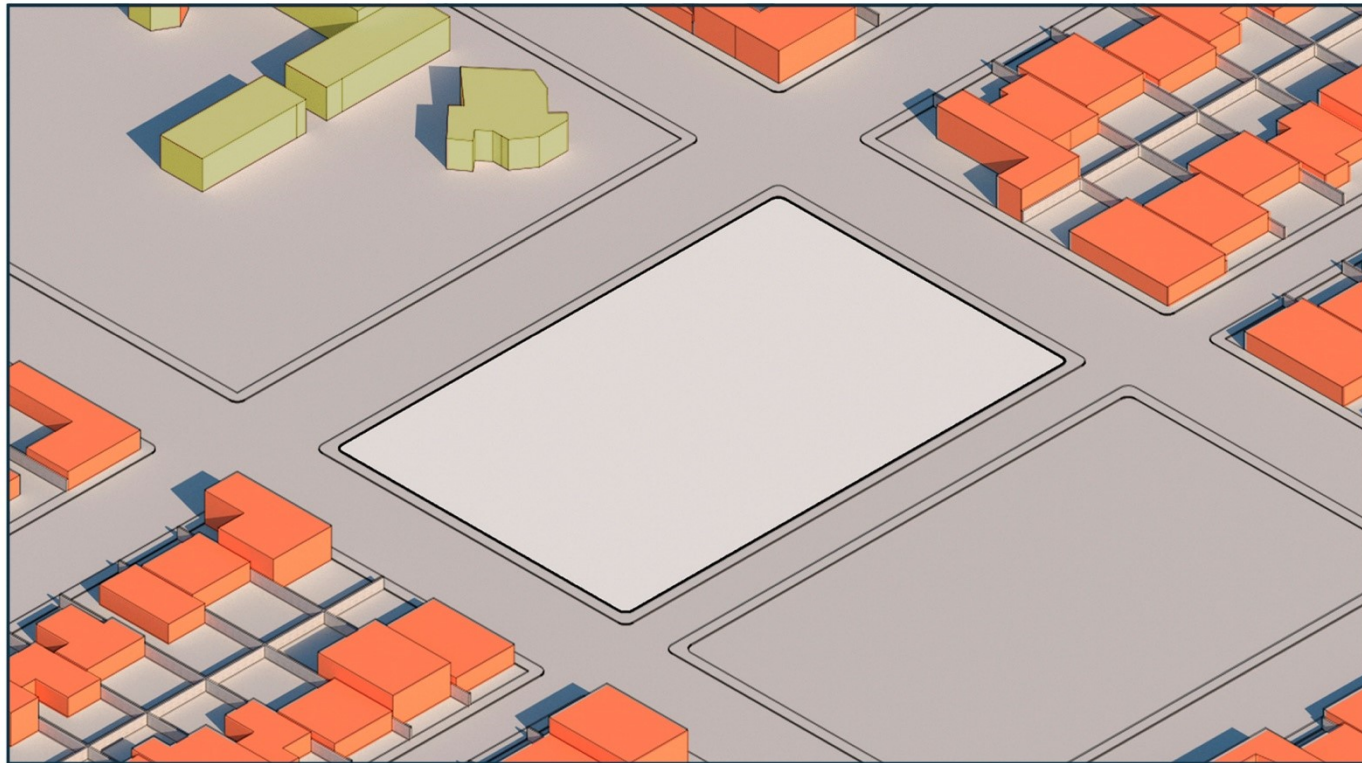

Tejido



### 03 | ESCALA SITIO

#### Análisis de Sitio



Vegetación

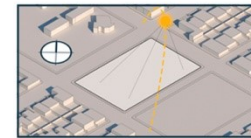
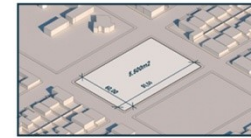

ESTU







¿ Qué queremos que pase?



### 03 | ESCALA SITIO

#### Programa

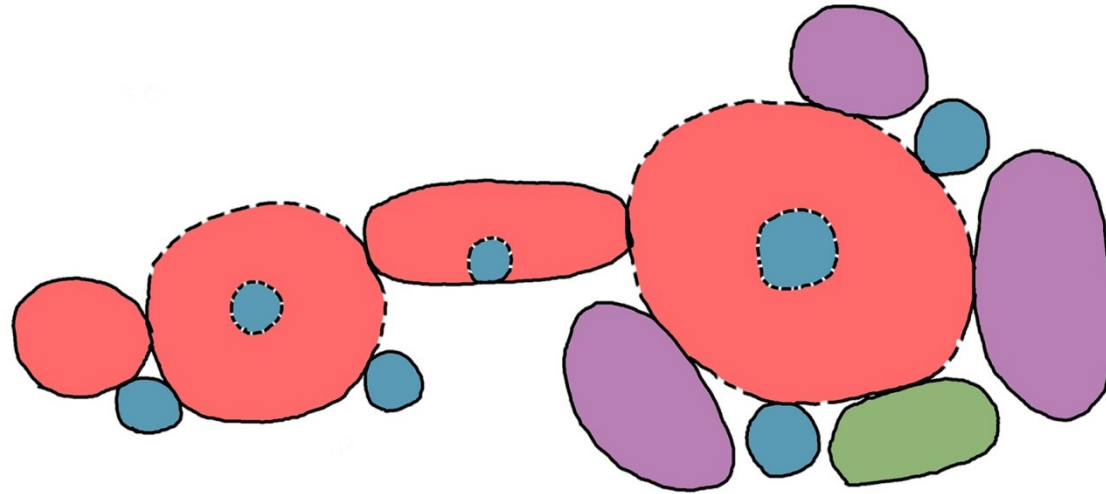



## 03 | ESCALA SITIO

### Programa

#### ESPACIOS SERVIDOS

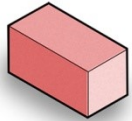

**AREAS  
COMUNES**  
1650m<sup>2</sup>

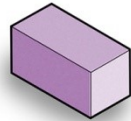

**AULAS**  
1290m<sup>2</sup>

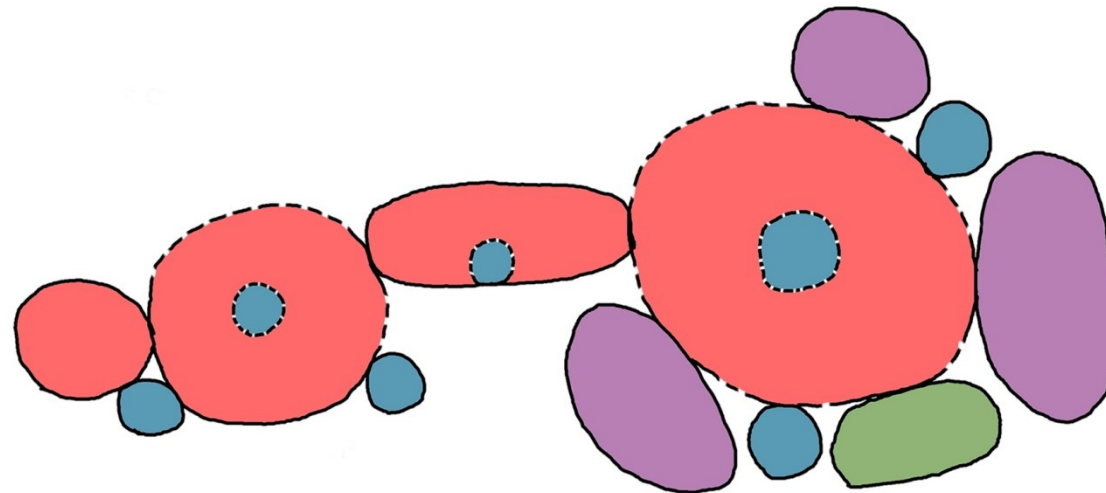

# 03 | ESCALA SITIO

## Programa

### ESPACIOS SERVIDOS

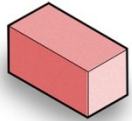

AREAS  
COMUNES  
1650m<sup>2</sup>

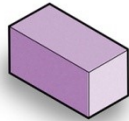

AULAS  
1290m<sup>2</sup>



### ESPACIOS DE SERVICIO

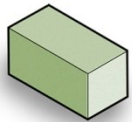

ADMINISTRACION  
255m<sup>2</sup>

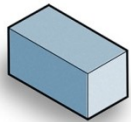

AREAS DE  
SERVICIO  
650m<sup>2</sup>

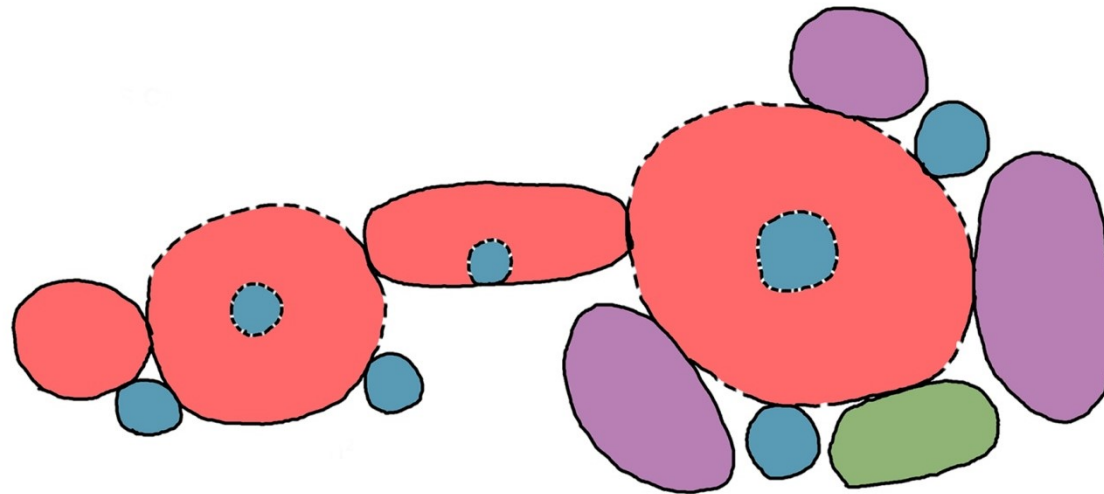



### 03 | ESCALA SITIO

#### Idea de Partido

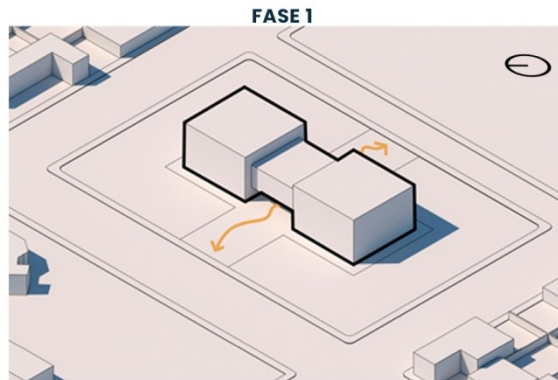

### 03 | ESCALA SITIO

#### Idea de Partido

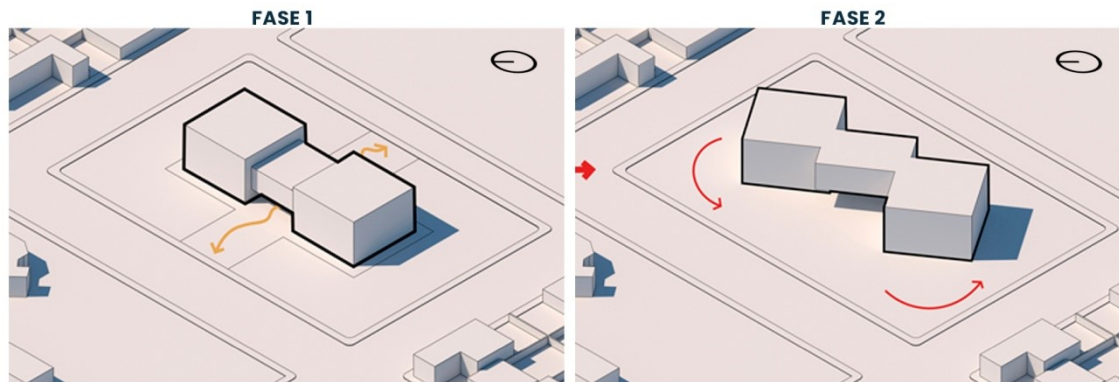

### 03 | ESCALA SITIO

#### Idea de Partido

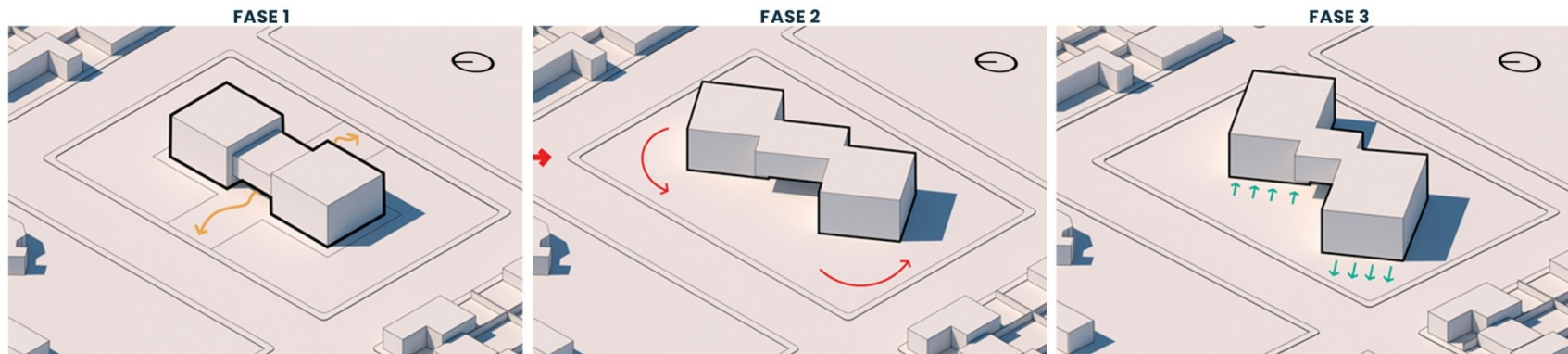



## 03 | ESCALA SITIO

### Idea de Partido

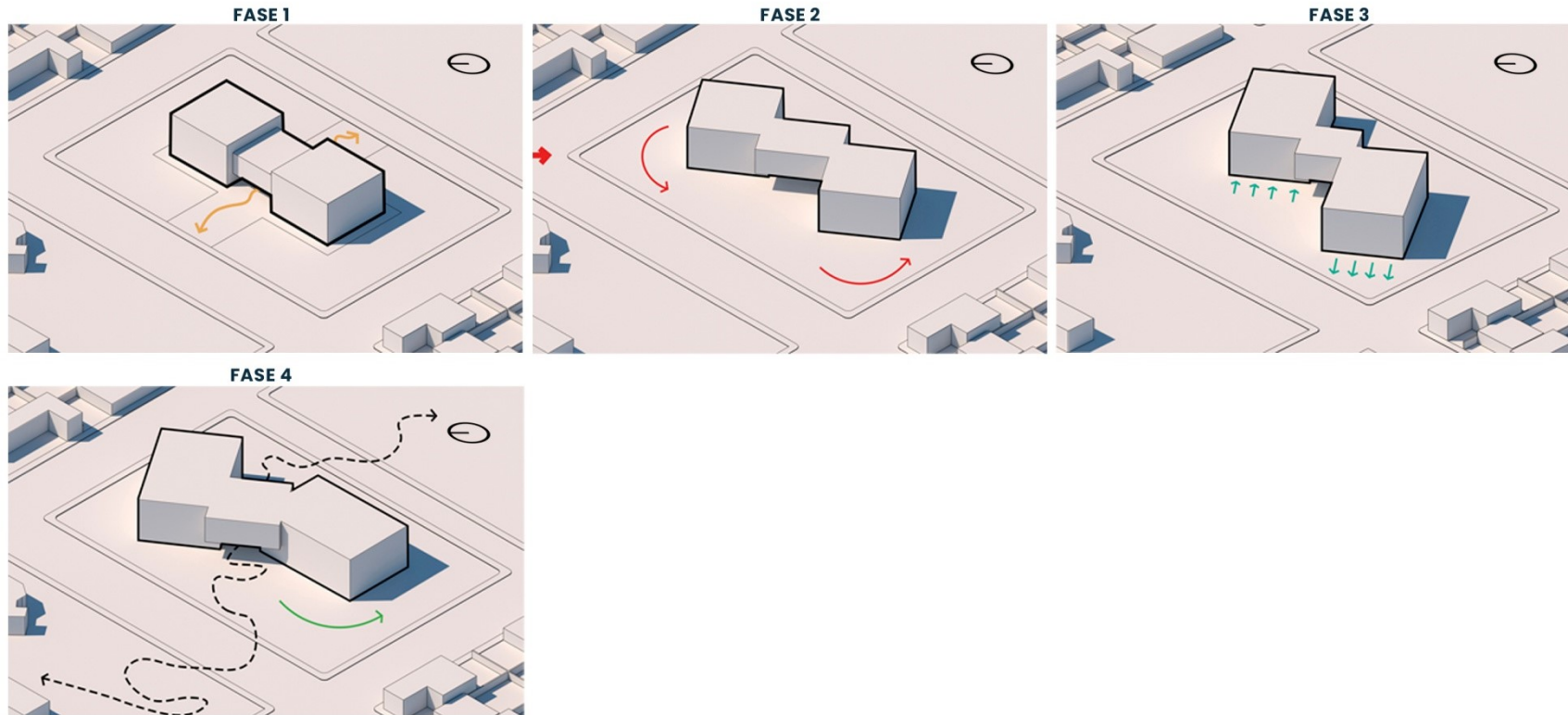

### 03 | ESCALA SITIO

#### Idea de Partido

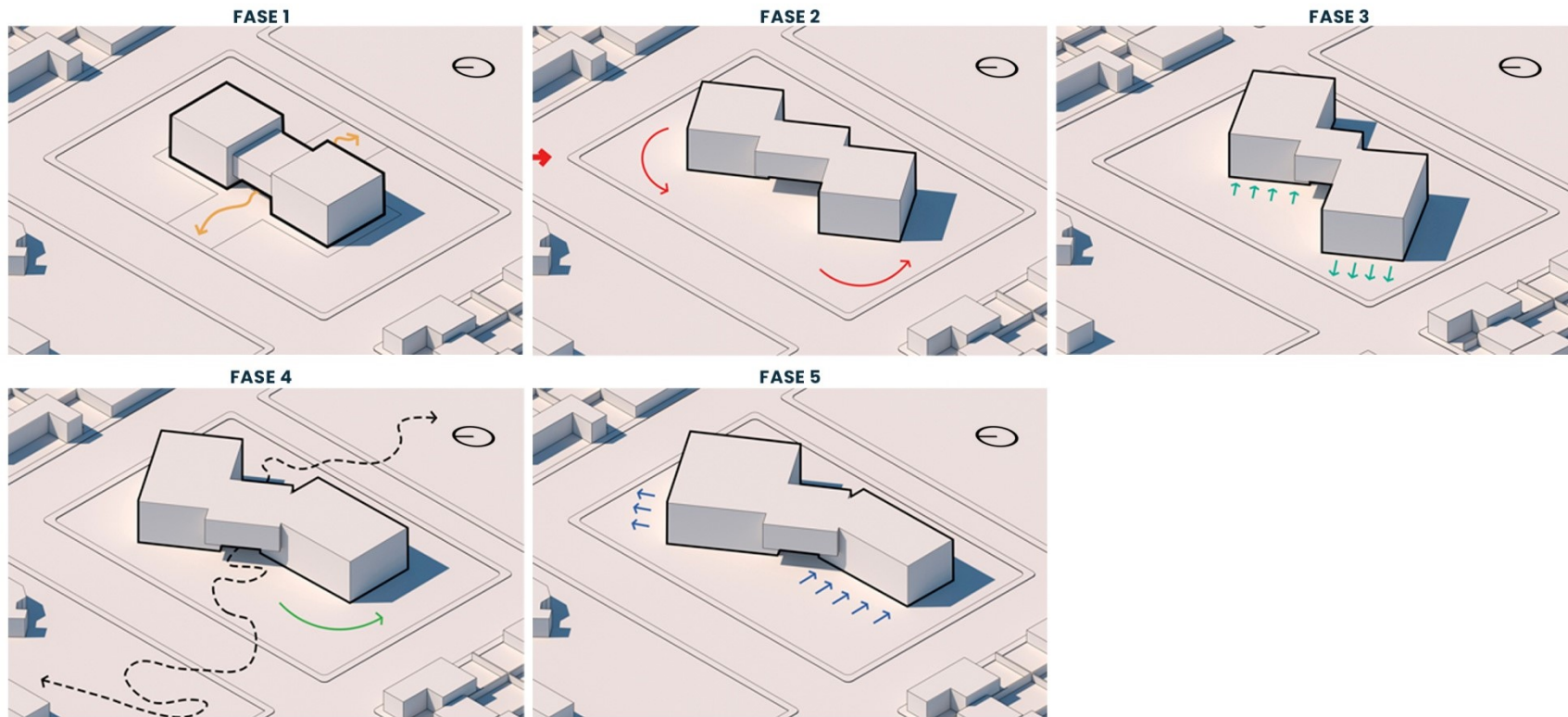

### 03 | ESCALA SITIO

#### Idea de Partido

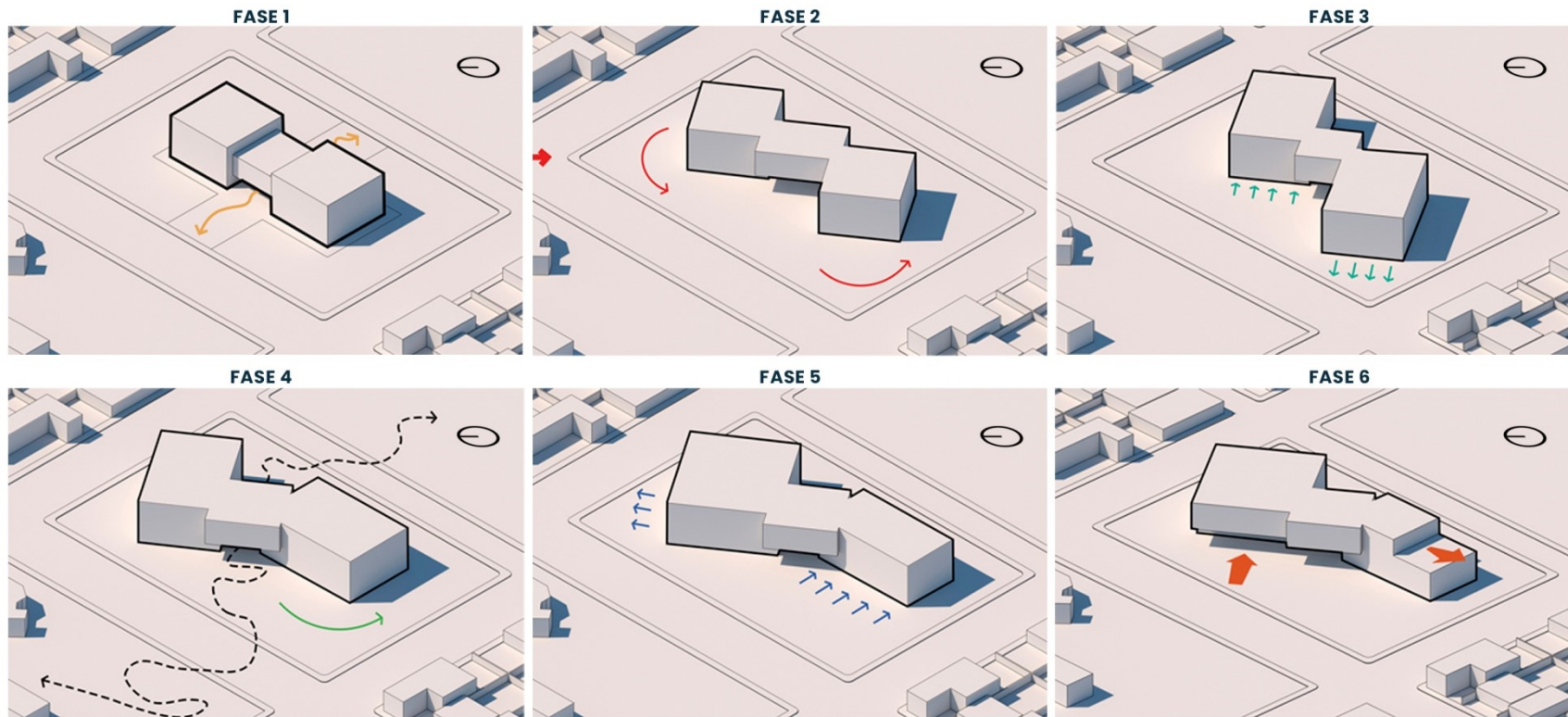



### 03 | ESCALA SITIO

#### Espacio Público

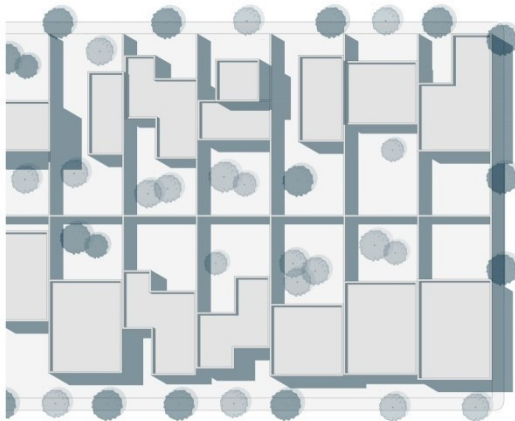
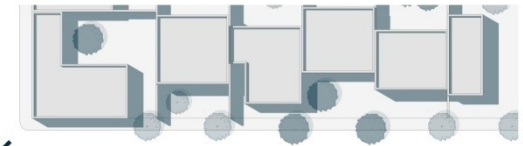
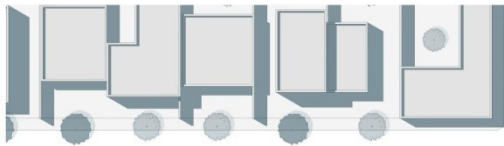

Av. CURAZAO



EDUARDO SOSA

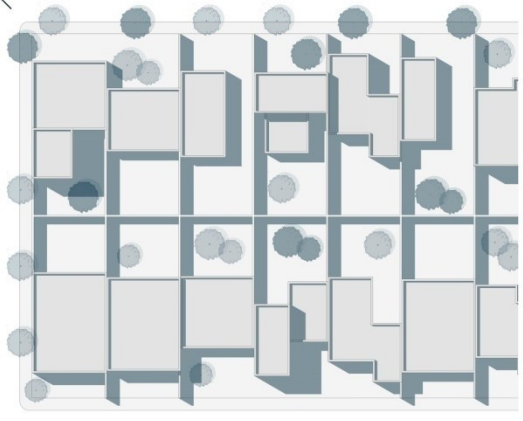

CABO ALFREDO ALEJANDRO GONZALEZ

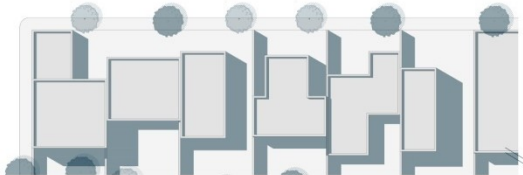

ESTU

















### 03 | ESCALA SITIO

#### Edificio



PLANTA BAJA

ESC: 1.100







### 03 | ESCALA SITIO

#### Edificio



PLANTA BAJA

ESC: 1.100







### 03 | ESCALA SITIO

#### Edificio



PLANTA BAJA

ESC: 1.100

ESTU



















### 03 | ESCALA SITIO

#### Edificio

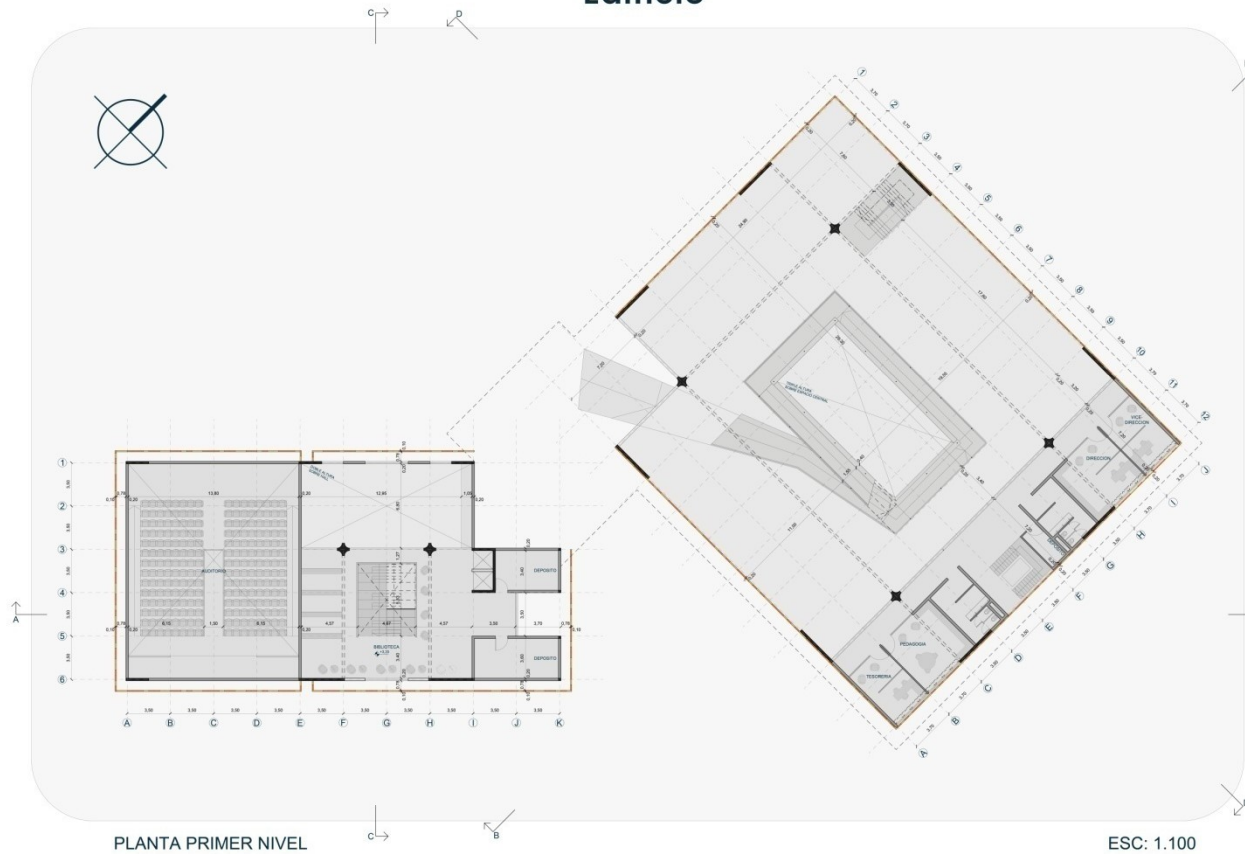



### 03 | ESCALA SITIO

#### Edificio



PLANTA SEGUNDO NIVEL

ESC: 1.100

















### 03 | ESCALA SITIO

#### Edificio

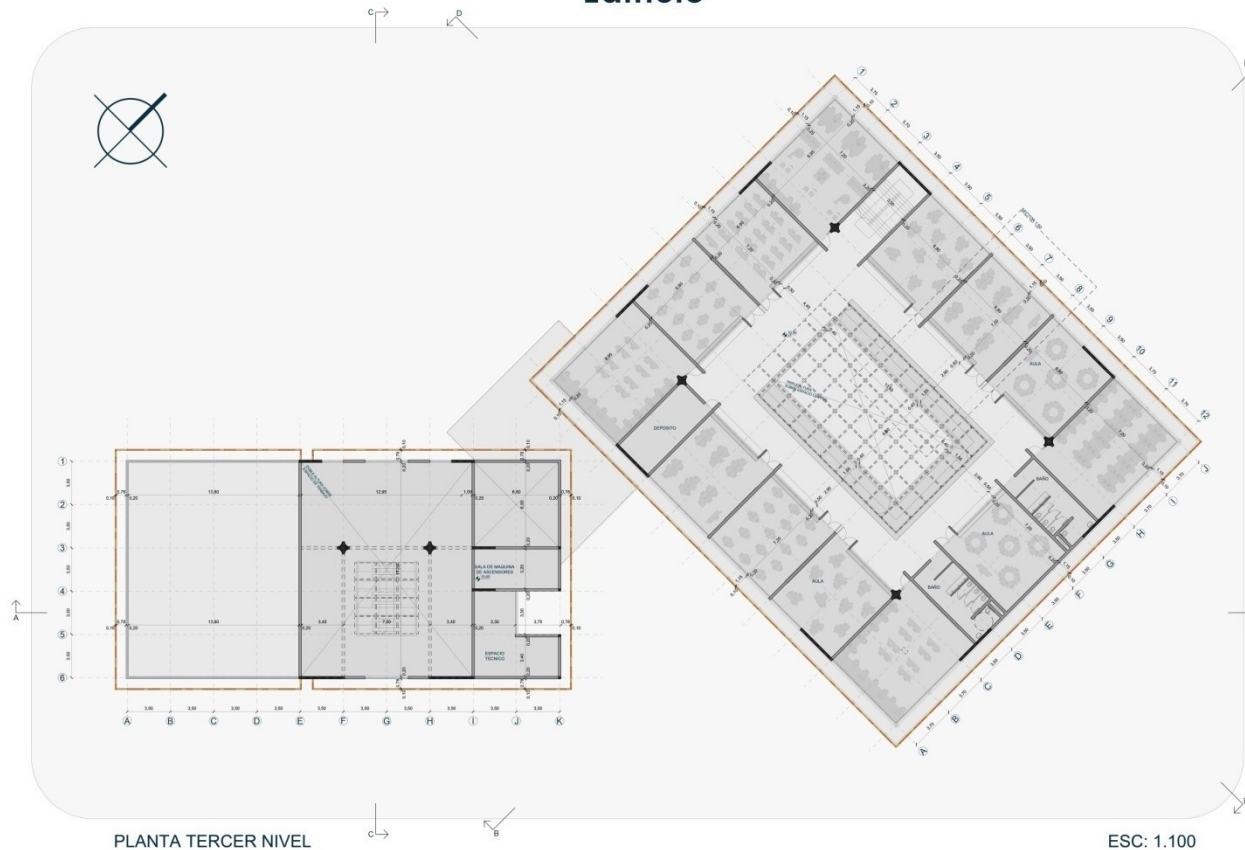



# 03 | ESCALA SITIO

## Edificio

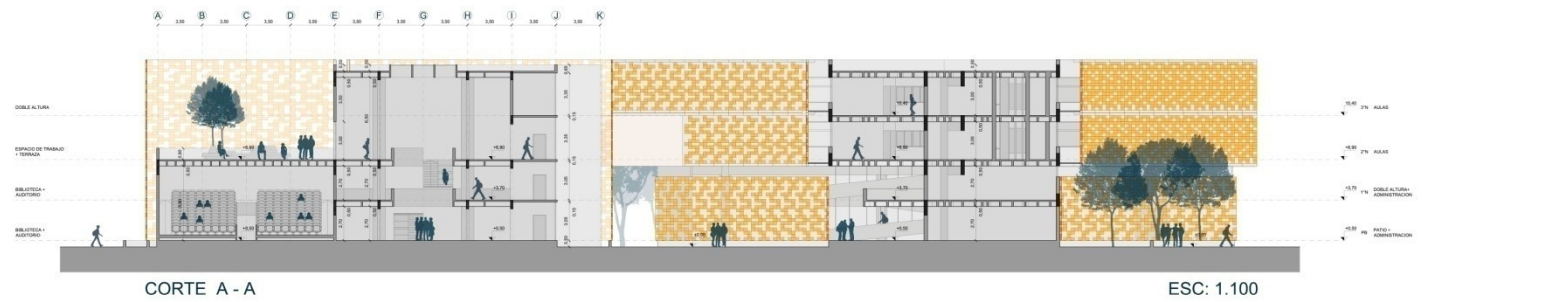

# 03 | ESCALA SITIO

## Edificio





# 03 | ESCALA SITIO

## Edificio

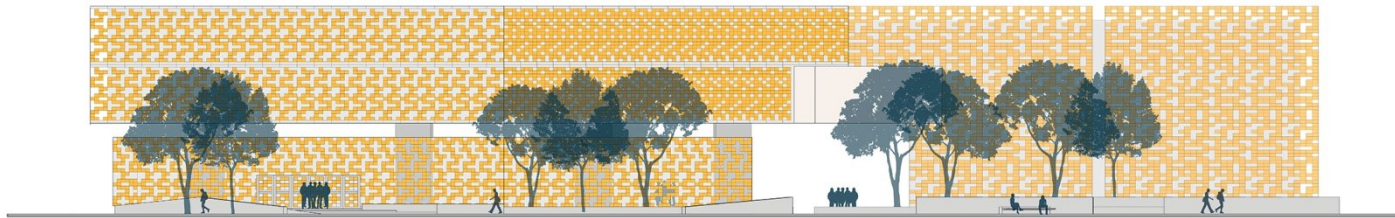

FACHADA NOROESTE

ESC: 1.100

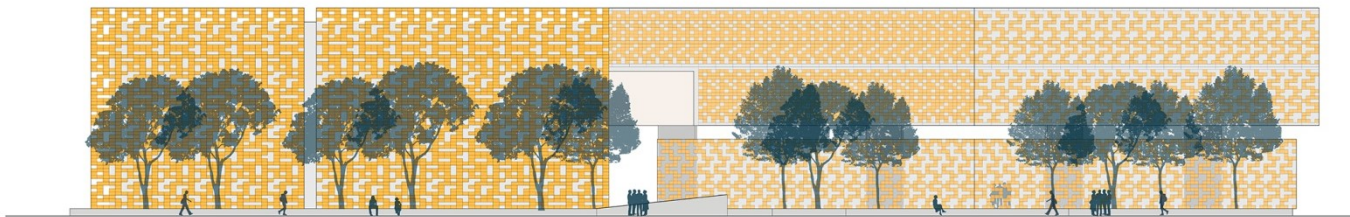

FACHADA SURESTE

ESC: 1.100



# 03 | ESCALA SITIO

## Espacio

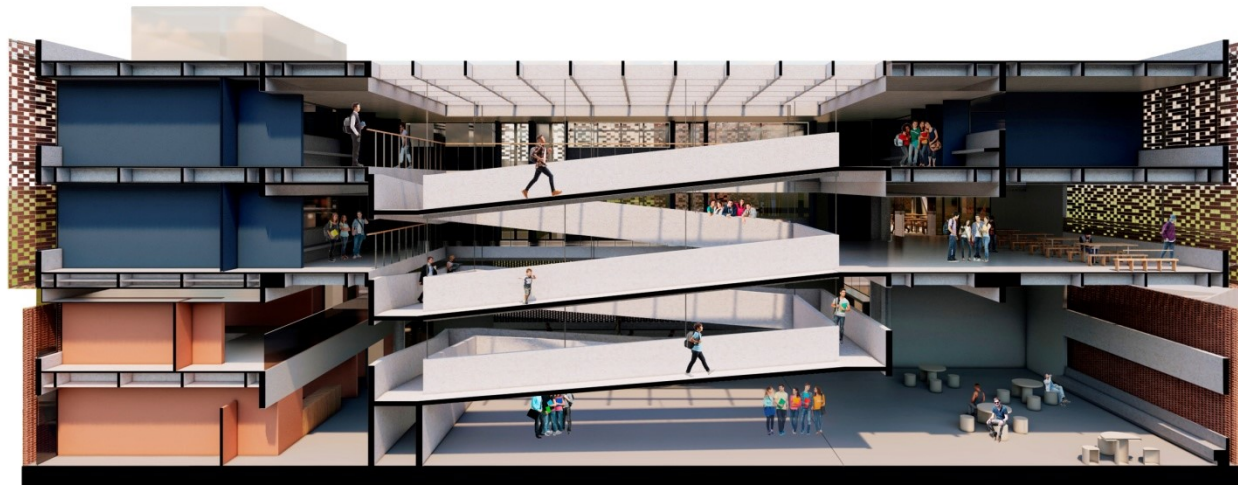

CORTE FUGADO

ESC: 1.50

### Bloque Educativo





### 03 | ESCALA SITIO

#### Equipamiento

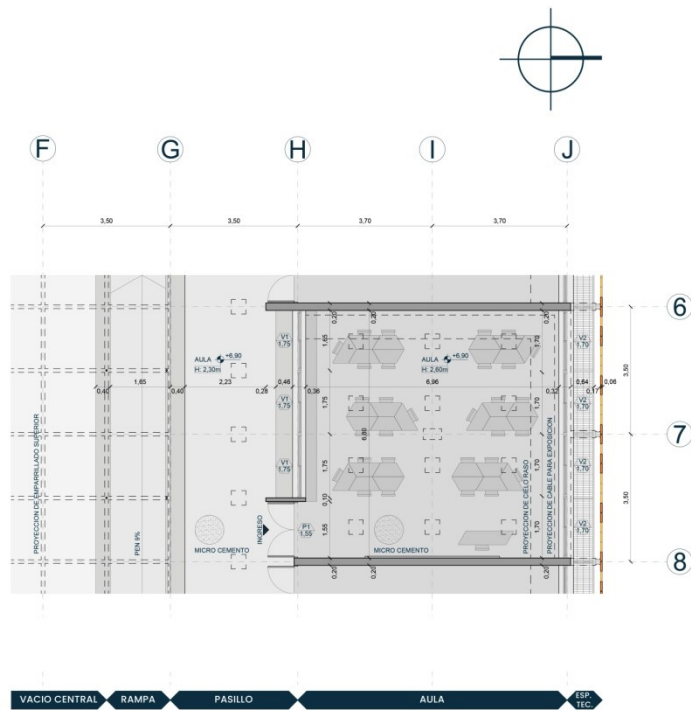

PLANTA

ESC: 1:50

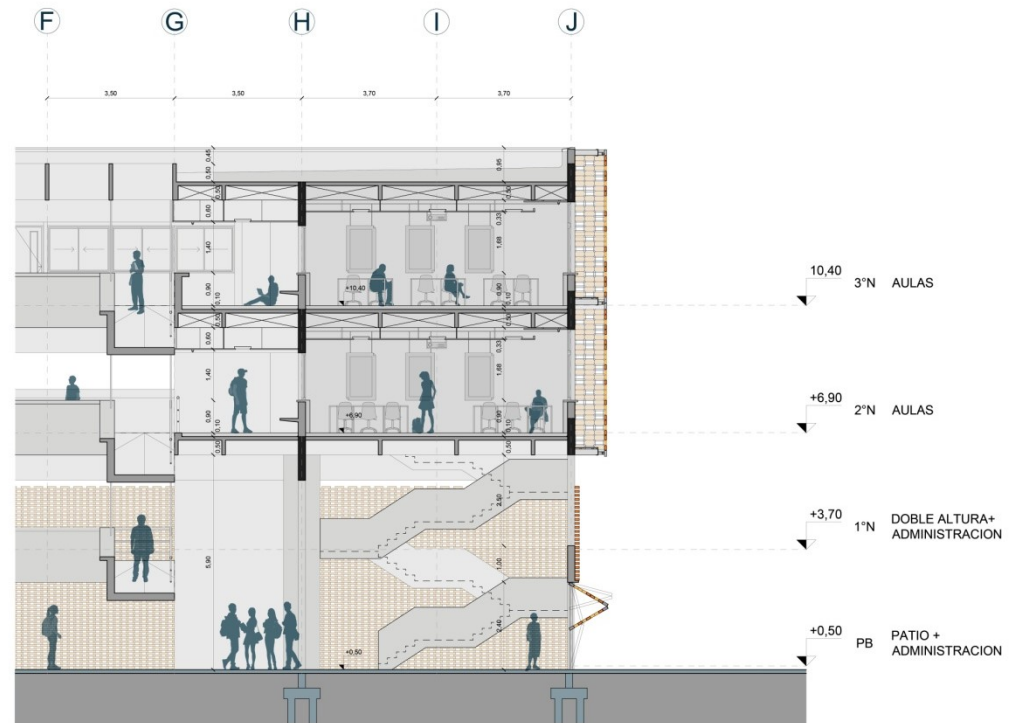

CORTE

ESC: 1:50







### 03 | ESCALA SITIO

#### Estructura

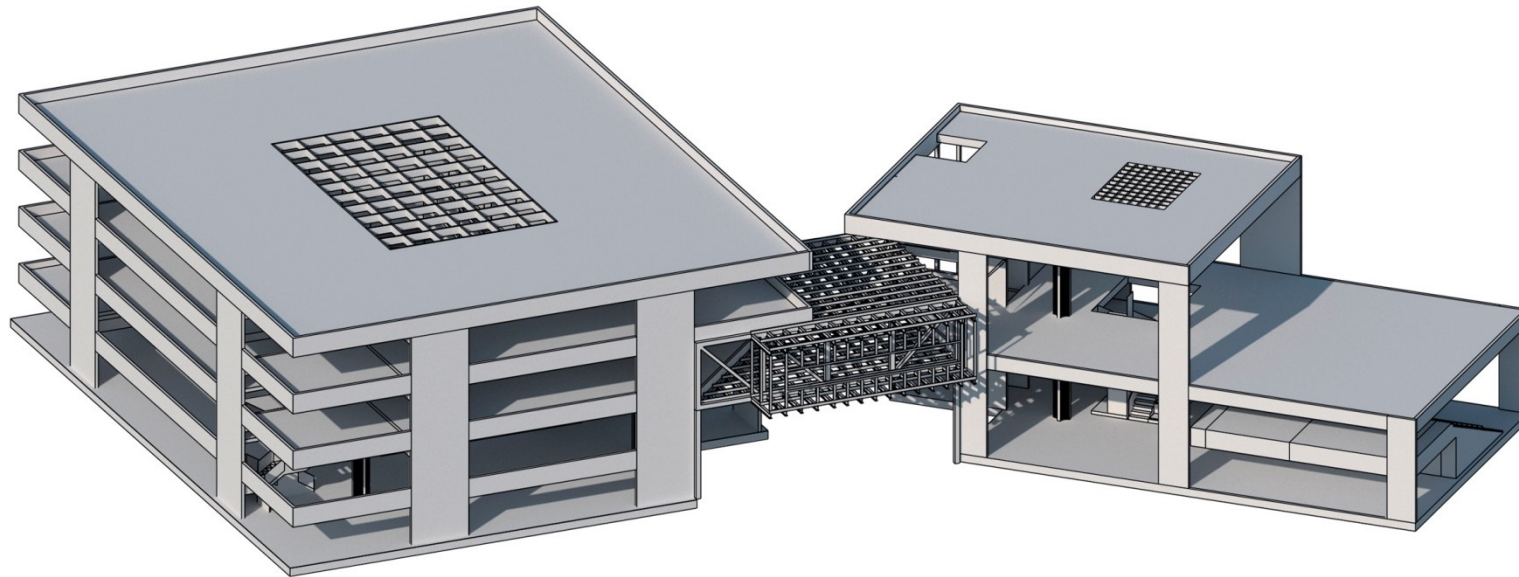

Esquema  
Estructural



03 | ESCALA SITIO  
Estructura

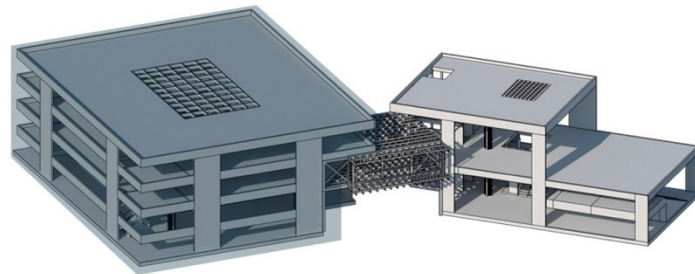

Esquema  
Estructural

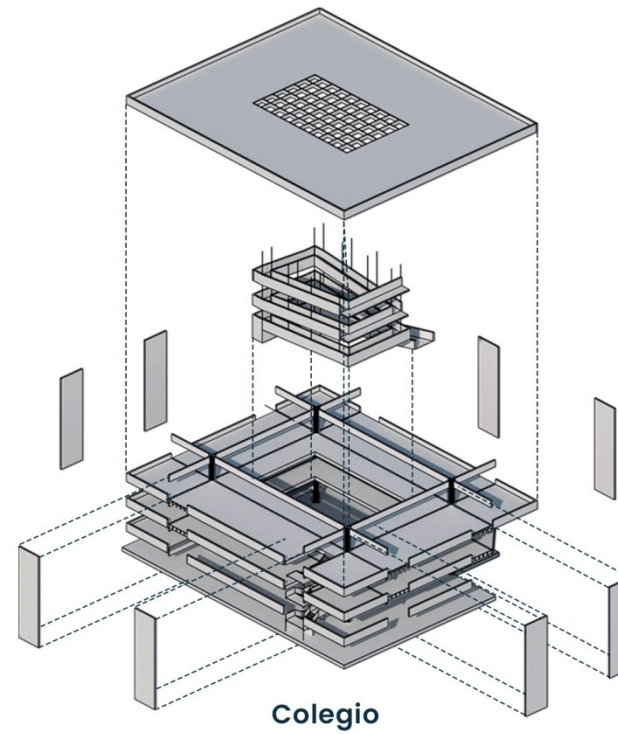

Colegio

03 | ESCALA SITIO

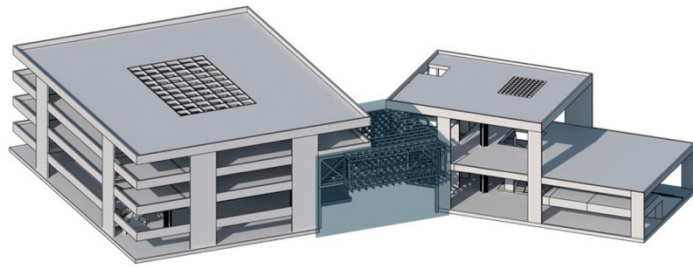

Esquema Estructural

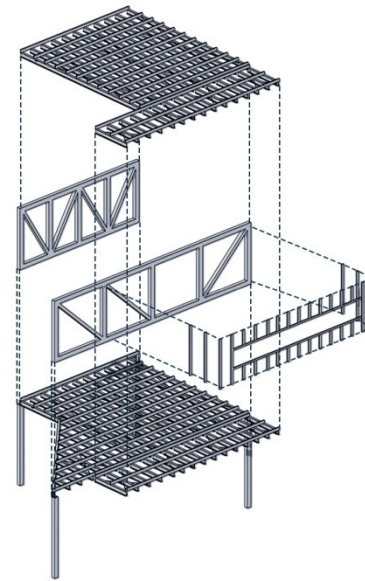

Comedor





03 | ESCALA SITIO

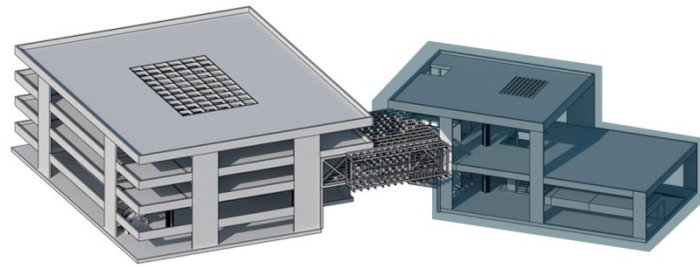

Esquema Estructural

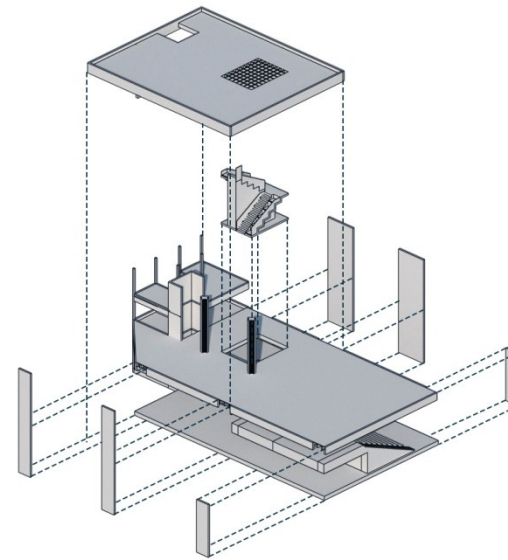

Biblioteca

### 03 | ESCALA SITIO

#### Tecnologia

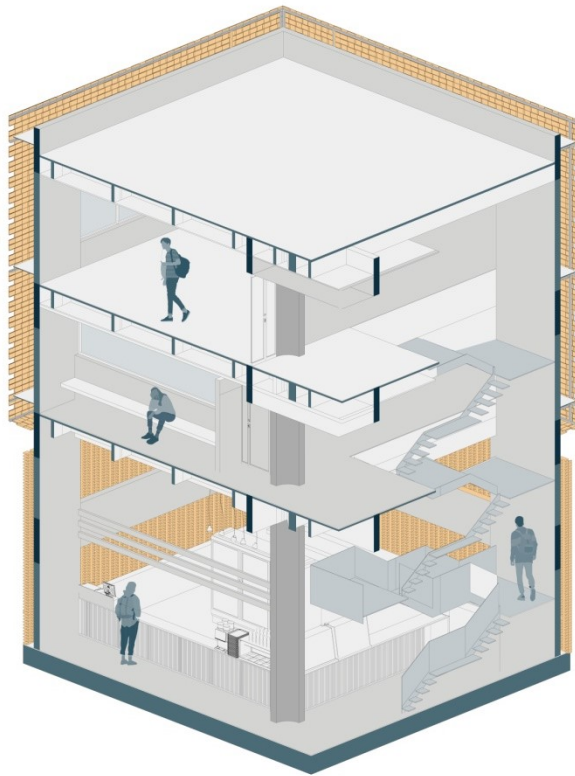

AXONOMETRICA

ESC: 1.20

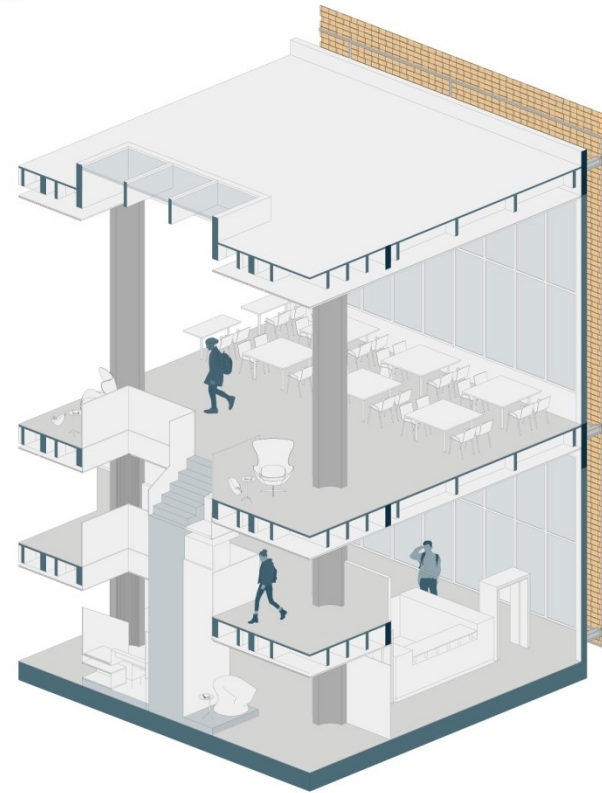

AXONOMETRICA

ESC: 1.20





### 03 | ESCALA SITIO

#### Tecnología

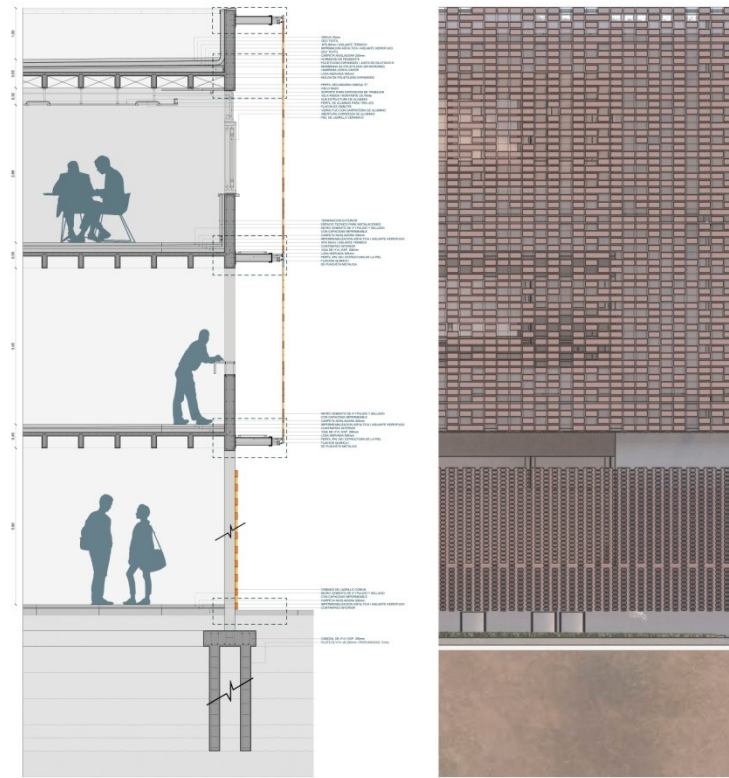

CORTE ESC: 1.20

FACHADA ESC: 1.20



# 03 | ESCALA SITIO

## Tecnología

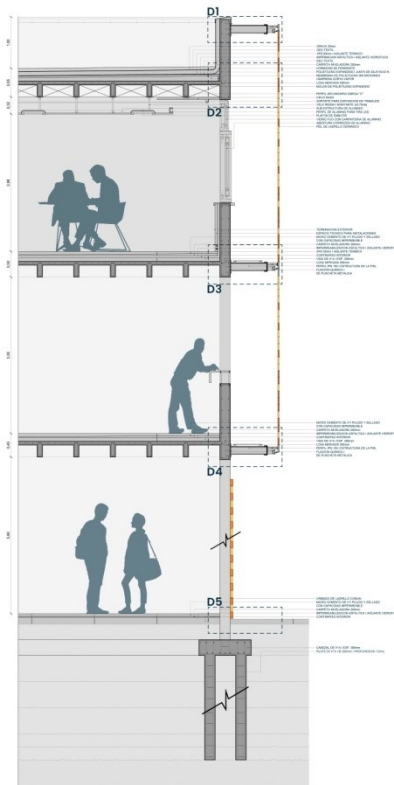

CORTE

ESC: 1:20

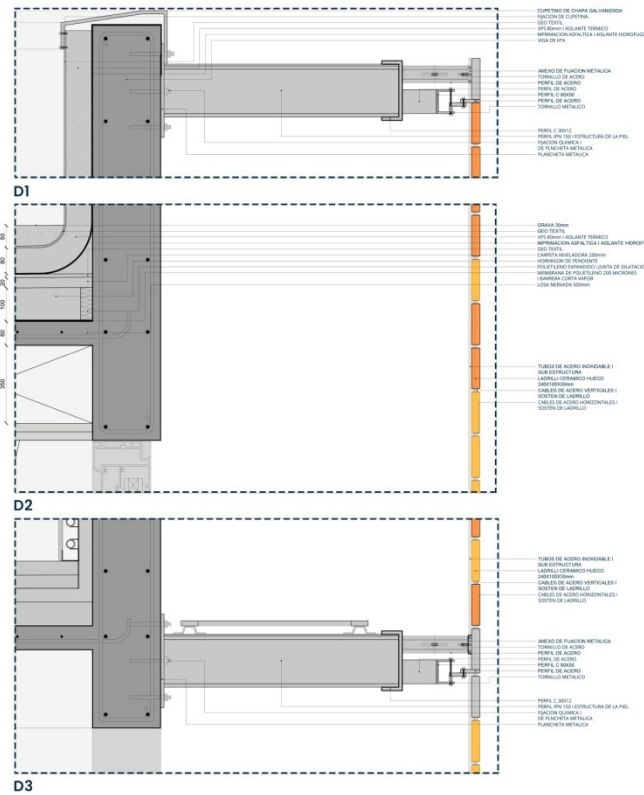

DETALLES

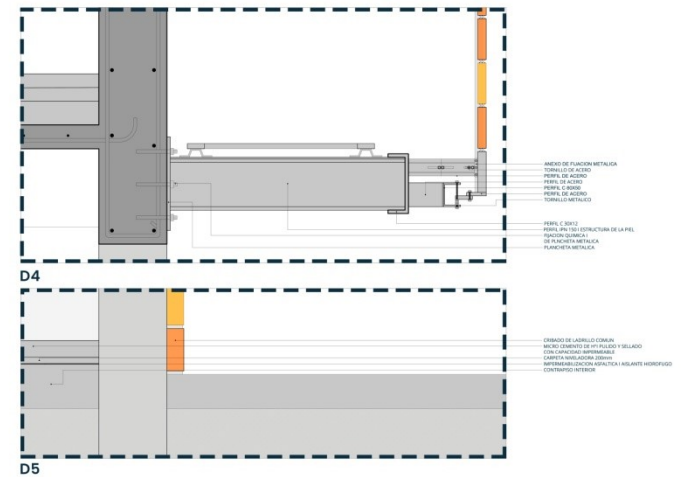

ESC: 1:5





# Situaciones de Movimiento



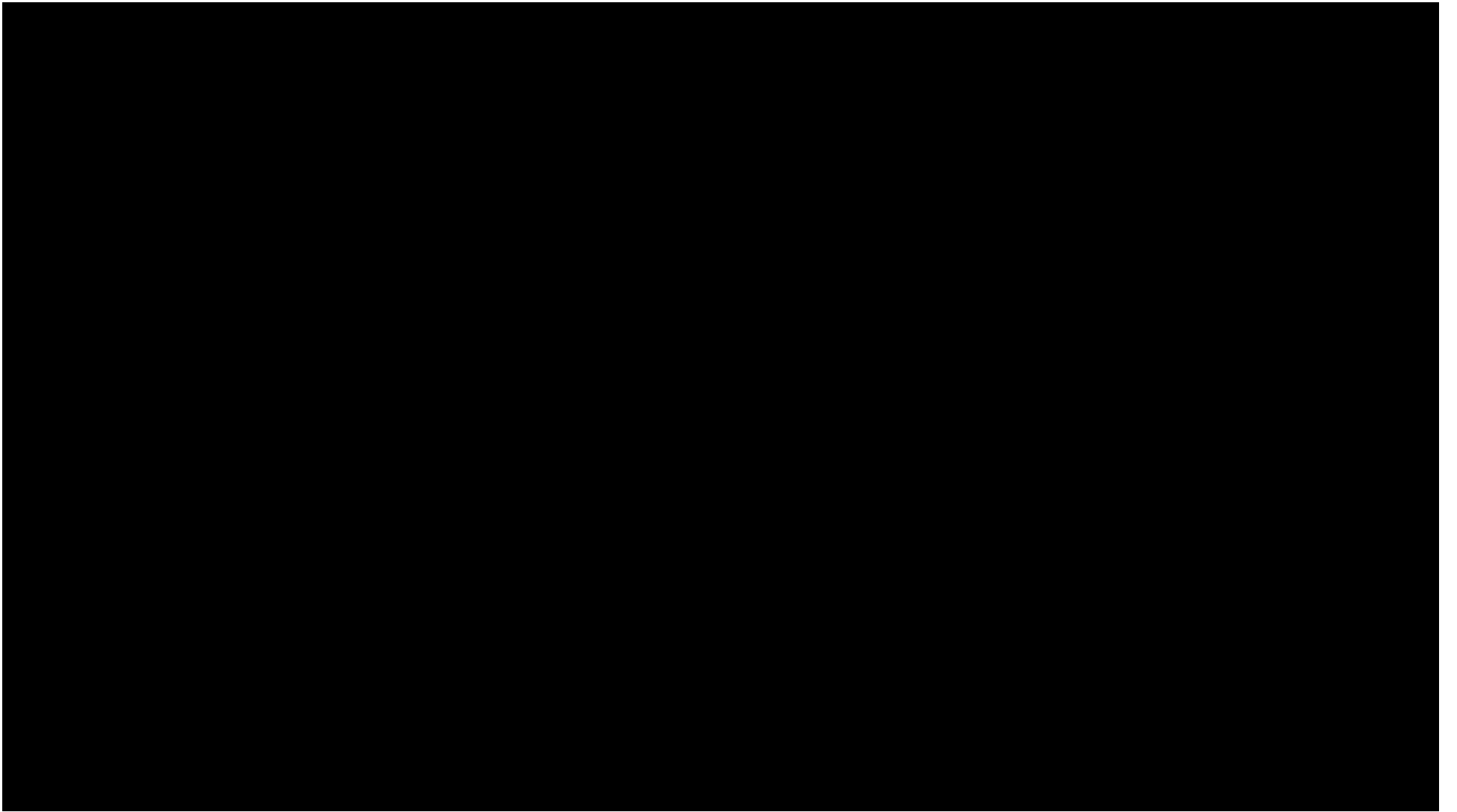



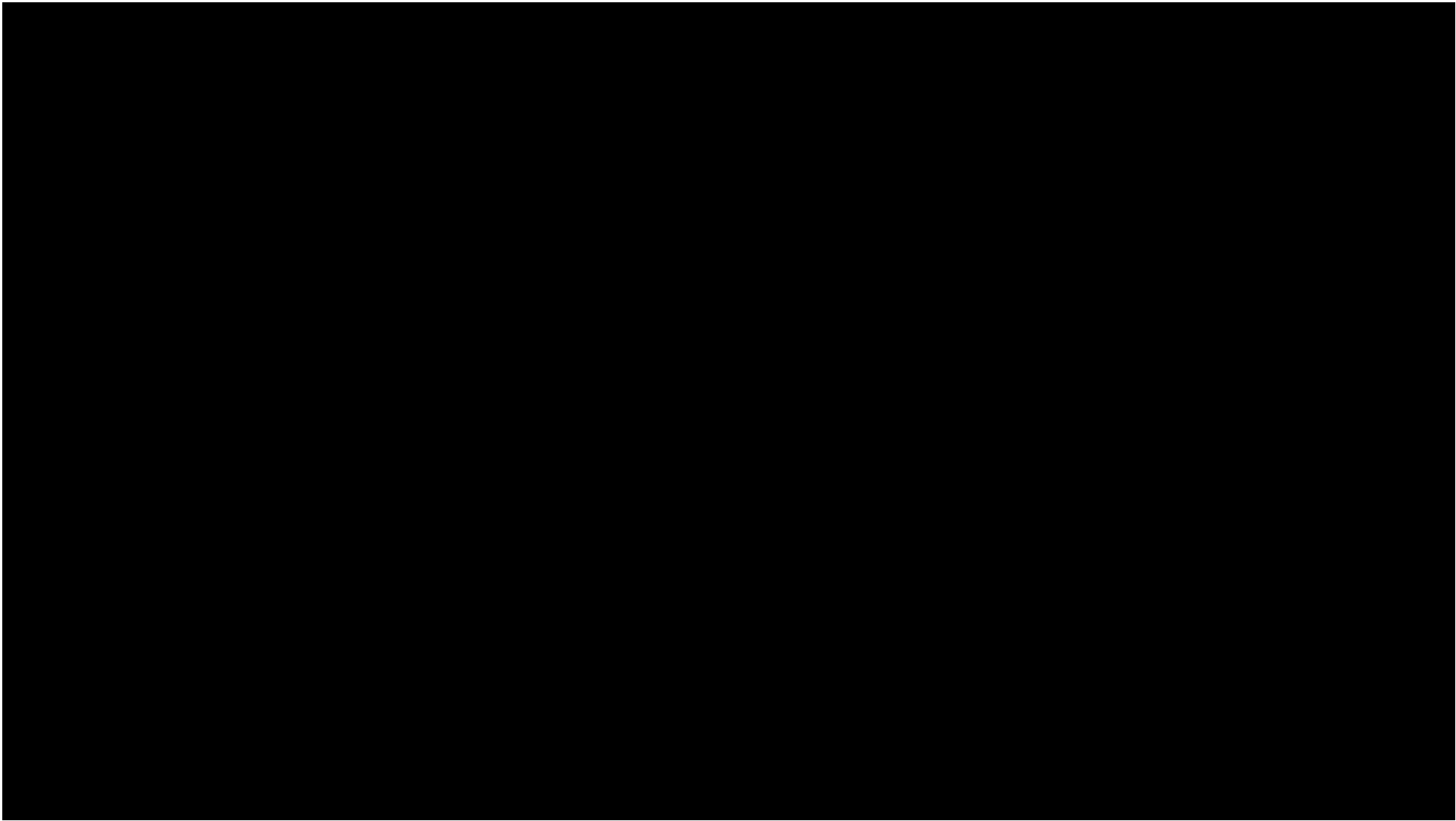

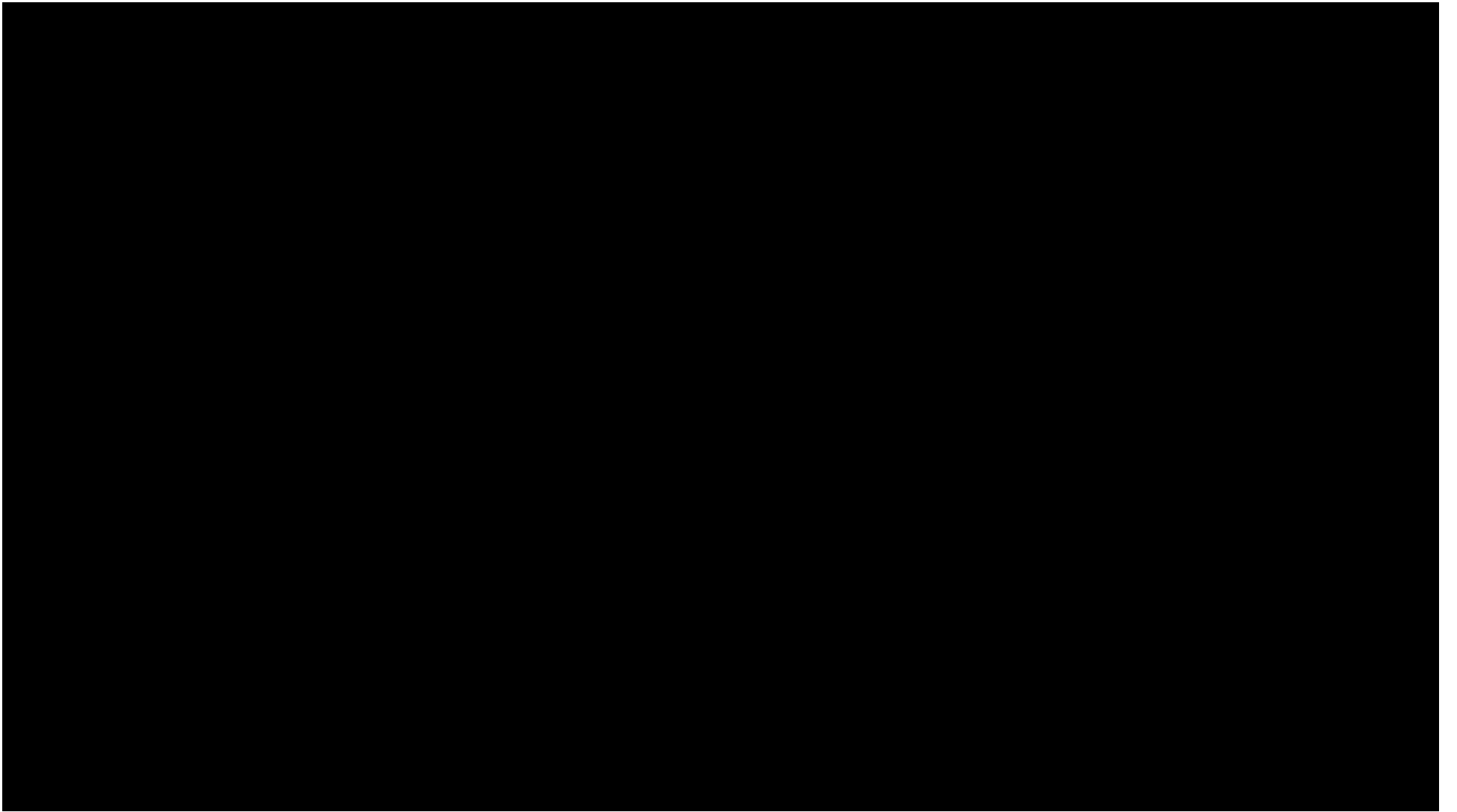



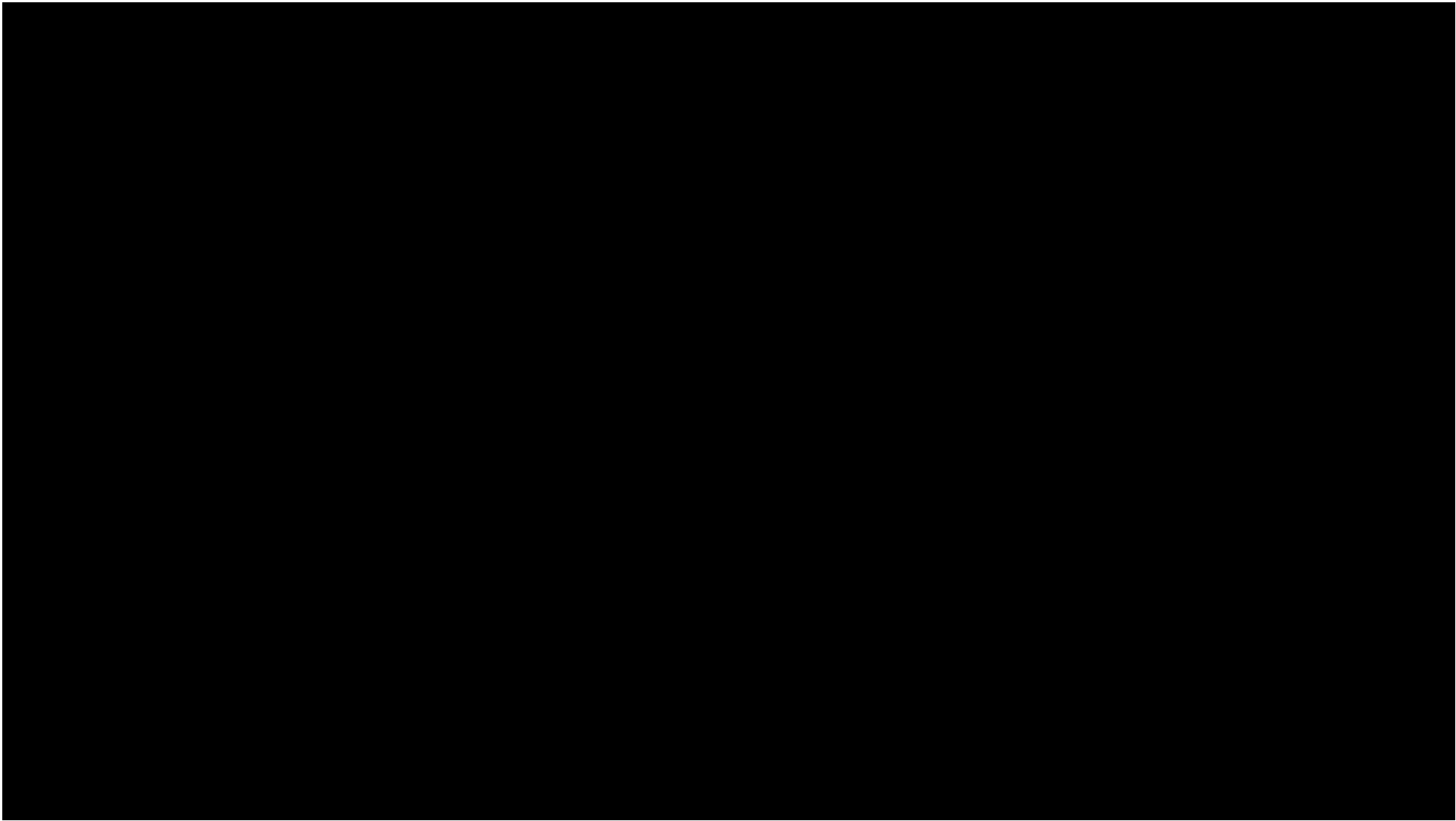





## 04 | CONCLUSIÓN



Revalorizar  
el área



Búsqueda  
Arquitectónica



Modernización  
Integral







## 04 | CONCLUSIÓN

**“El origen de la arquitectura está en lo público”**

Herman Hertzberger

